

Rev.	Description	Initiator	Date
02	Combination Drawing for DAQ and NET	CCS	1/20/2010

Customer machines mounting pattern as needed in plate. Remove plate prior to machining.

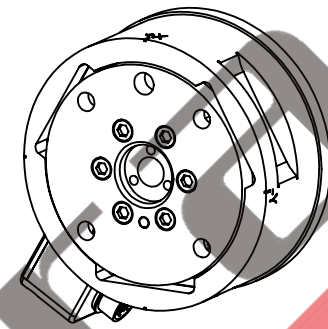
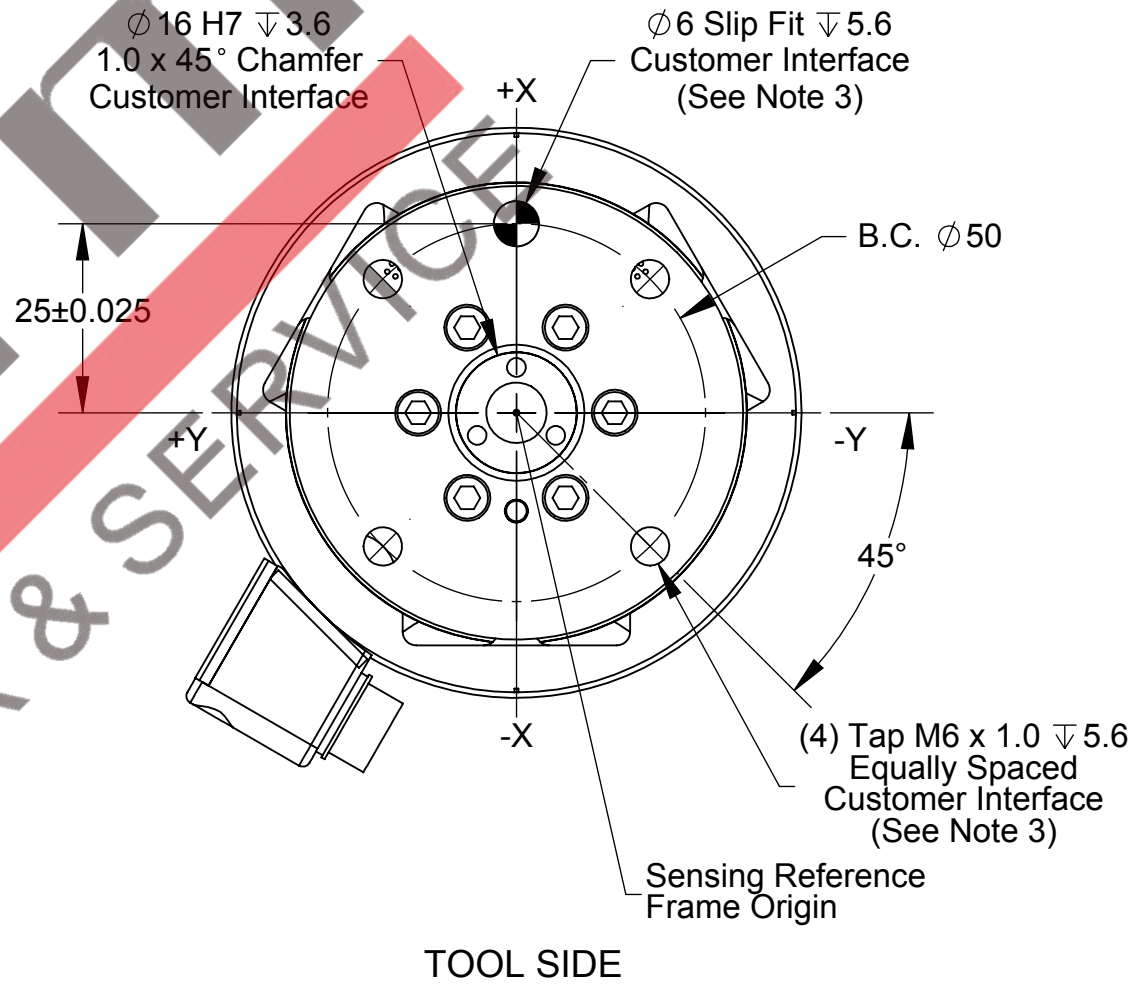
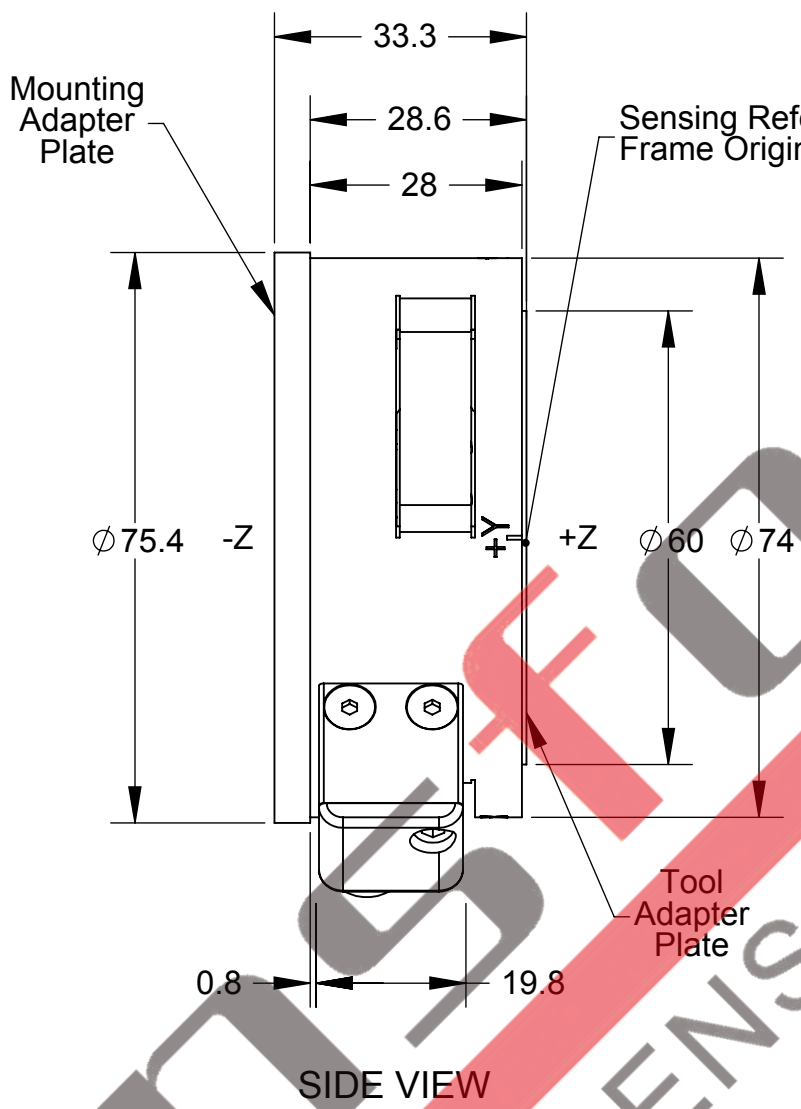
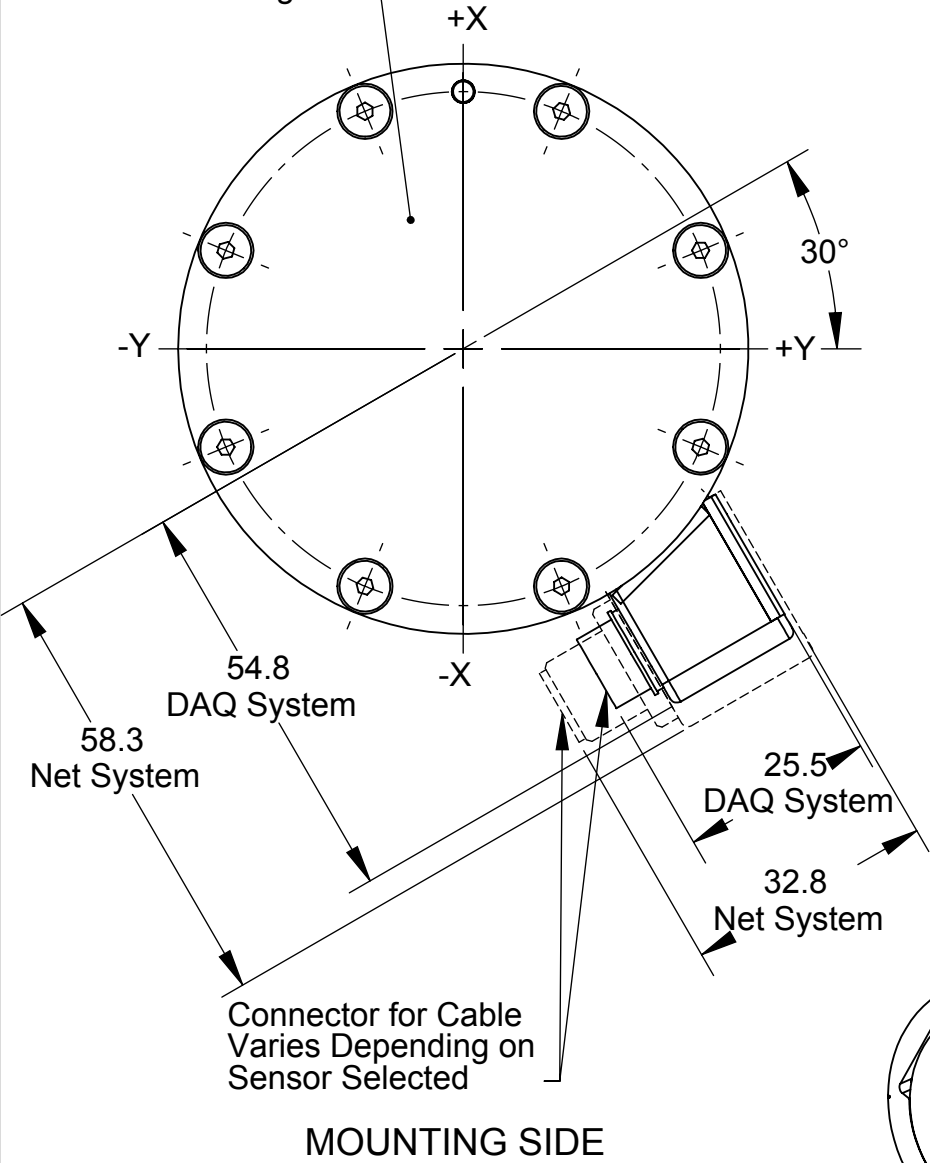

- Notes:
1. Material: Aluminum.
  2. Do Not Touch internal electronics or instrumentation this could damage the transducer and will void the warranty.
  3. **DO NOT EXCEED INTERFACE DEPTH, MAY CAUSE DAMAGE.**
  4. Transducer must be mounted to surfaces rigid enough to support loads without deflection for best accuracy.

NOTES: UNLESS OTHERWISE SPECIFIED  
DO NOT SCALE DRAWING. DRAWN IN SOLIDWORKS.  
ALL DIMENSIONS ARE IN MILLIMETERS.

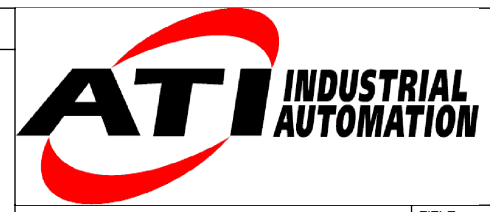
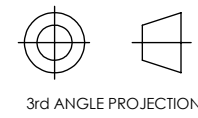

1031 Goodworth Drive, Apex, NC 27539, USA  
Tel: +1.919.772.0115 Email: info@ati-ia.com  
Fax: +1.919.772.8259 www.ati-ia.com  
ISO 9001 Registered Company

PROPERTY OF ATI INDUSTRIAL AUTOMATION, INC. NOT TO BE REPRODUCED IN ANY MANNER EXCEPT ON ORDER OR WITH PRIOR WRITTEN AUTHORIZATION OF ATI.

DRAWN BY: D. Swanson 11/05/08		TITLE: Gamma Transducer	
CHECKED BY: R. Chambers 11/06/08		SCALE: 1:1	SIZE: B
WEIGHT LBS: -----		DRAWING NUMBER: 9230-05-1329	
ASSEMBLY REF:		PRODUCT RELEASE #	DATE:
		SHEET 1 OF 1	