



LOW-COST OEM PRESSURE TRANSDUCER

MODEL 1002 / 1003

FEATURES:

- Low-cost, high reliability
- Up to 0.25% FSO accuracy
- Compact 0.870" diameter
- Rugged, all welded construction
- NEMA - 4X/IP65 rated
- CE Approved: EN 50 081-1

APPLICATIONS:

- Automotive
- Industrial OEM
- On-board vehicle
- Compressor controls
- Pneumatic/hydraulic controls
- Pump controls

PRODUCT OVERVIEW:

The Model 1002/1003 from GP:50 is a family of lower cost, industrial grade OEM pressure transducers, featuring corrosion-resistant, all stainless steel wetted parts and housings. Series transducers are ideal for higher volume pressure monitoring applications, particularly where lower costs are required, yet where the need for precision measurement accuracy remains. Units are available with choice of 4-20 mA, 0 to 5 Vdc or 0 to 10 Vdc output, as well as various electrical connection and pressure port options. Typical applications for the Model 1002/1003 include off-road vehicle, HVAC/R, hydraulic and pneumatic control systems, pumps and compressors, and industrial engine pressure monitoring.

FIELD OPTIONS:

- Vdc & 4-20 mA output
- Alternate connectors & pressure ports



1002 / 1003
Low-Cost OEM Pressure Transducer

GP:50 MODEL 1002 / 1003

DIMENSIONAL DRAWING

All dimensions are in inches (mm)

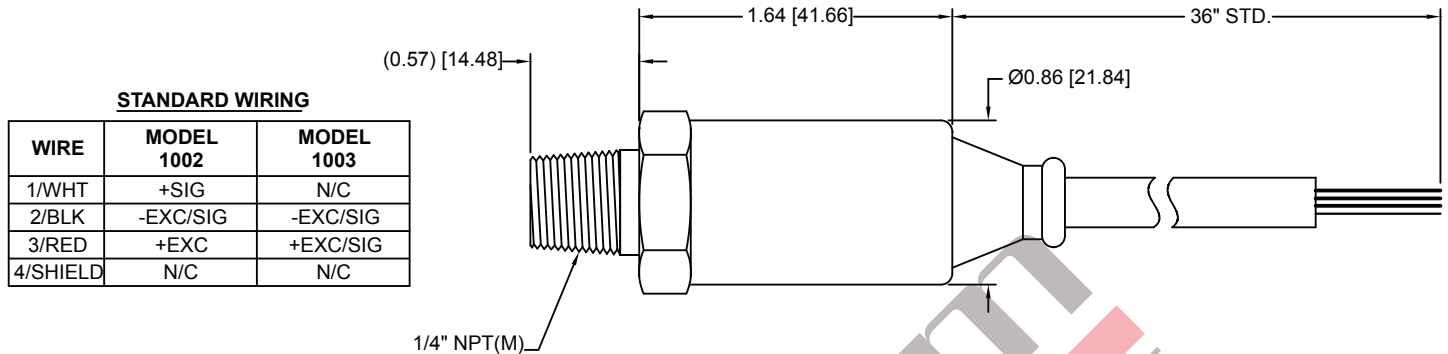

REFERENCE SPECIFICATIONS

ELECTRICAL	MECHANICAL
<ul style="list-style-type: none"> • Supply Voltage: 9 to 36 Vdc • Output Signal: (1002) 0 to 5 Vdc, 0 to 10 Vdc optional (1003) 4-20 mA • Load Resistance: 3.5 mA nominal, 6 mA max. • Approvals: CE EN 50 081-1 • Response Time: <5 ms • Connection: 36" long Belden 8723, 24 AWG, 4 conductor cable 	<ul style="list-style-type: none"> • Process connection: 1/4" NPT (M) standard (other options available) • Proof Pressure: 1.5X FSO • Burst Pressure: 3X FSO or 17,500 PSIG (1,207 BAR), whichever is less • Weight: <4 oz (113 g)
STATIC ACCURACY (BFSL) (HYSTERESIS, NON-LINEARITY & REPEATABILITY @ +70 °F)	PRESSURE RANGES
Standard: ±0.5% FSO Improved: ±0.2% FSO	<ul style="list-style-type: none"> • 0 to 5 thru 0 to 10K PSI (0.3 thru 689 BAR), gauge, vacuum, and absolute pressure reference available
MATERIALS OF CONSTRUCTION	THERMAL SPECIFICATIONS
<ul style="list-style-type: none"> • Wetted Parts: 316 stainless steel and 17-4 stainless steel • Housing: 316 stainless steel 	<ul style="list-style-type: none"> • Compensated: 0 °F to +180 °F (-17.7 °C to +82 °C) • Operating Temperature: -40 °F to +180 °F (-40 °C to +82 °C) • Storage: -40 °F to +250 °F (-40 °C to +121 °C) • Effect on Zero/Span: < ±2.0% FSO/100 °F

All specifications are for reference purposes only. In the interests of continuous product improvement, all specifications are subject to change without notice. Please contact GP:50 for assistance with your application.