

## MUD GAUGE DIAPHRAGM TYPE

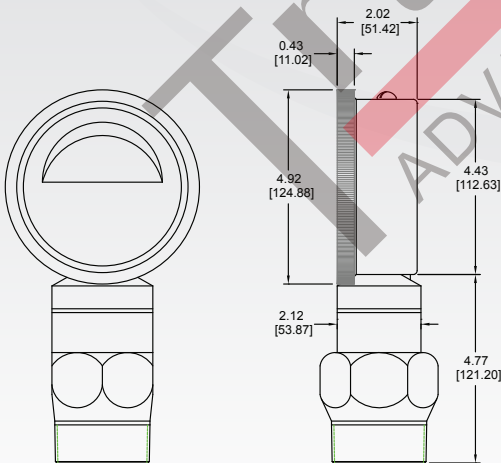

GPMG Series  
Mud Gauge Diaphragm Type



### GPMG SERIES

#### FEATURES:

- Pressure range from 5K PSI to 15K PSI (345 to 1,034 BAR)
- Socket and case welded for high vibration and corrosive service
- Fixed pointer and movable dial
- 4" glycerin filled dial
- Weather proof/anti-corrosive gun metal casting
- Easy-to-read analog display

#### APPLICATIONS:

- Mud pump pressure
- Stand pipe pressure
- Oil and gas well head pressures

#### TECHNICAL SPECS:

- Bourdon tube: 316 stainless steel
- Movement: 304 stainless steel
- Diaphragm: 316L stainless steel
- Casing: Anti-corrosion treated carbon steel
- Process connection: Bottom mount 2" NPT
- Static accuracy: 2.5% FSO
- Pressure ranges: 0 to 10K PSI thru 0 to 15K PSI (690 thru 1,034 BAR)
- Dial: 4" Glycerin filled plexiglass
- Neoprene rubber pad for mud protection

**Standard configurations shown.  
Please consult factory for other options.**