

## DRY, NON-FILLED DIGITAL PRESSURE GAUGE

### MODEL DG-11

#### FEATURES:

- Simple two-button operation
- Zero reset button
- Auto restore for last pressure reading
- Back-lit LCD display
- Overload display function
- Vacuum, compound and absolute ranges
- 2x proof pressure, 5x burst pressure

#### TECHNICAL SPECS:

- 3" Dial (3.2" with rubber boot)
- 1.85" x 0.65" backlit LCD Display
- Unit display: PSI, BAR, Kg/cm<sup>2</sup>  
(Calibration record provided in Pa, KPa, MPa)
- Optional USB, RS-485, RS-242 outputs
- Optional NIST traceable calibration
- 1/4" NPT pressure port, SAE4, 1/8" NPT, optional 1/4" BSP
- Valox™ 420 case material, 17-4 PH stainless steel standard pressure port (alternate materials available)
- **Approximate weight:** 8 oz
- **Accuracy:** ±0.5% FSO standard, includes linearity, hysteresis, and repeatability, 0.25% FSO and ±0.1% FSO optional
- **Thermal error:** 0.0001% FSO/ °F
- **Calibrated temperature range:** +35 °F to +130 °F
- **Operating temperature:** +15 °F to +140 °F
- **Storage temperature:** -5 °F to +160 °F
- **Power source:** 9V battery
- Automatic power off (5 minutes with LOW BATT indicator)
- Optional protective rubber boot
- NEMA 4/IP65 enclosure
- Optional oxygen cleaning



DG-11  
Digital Pressure Gauge

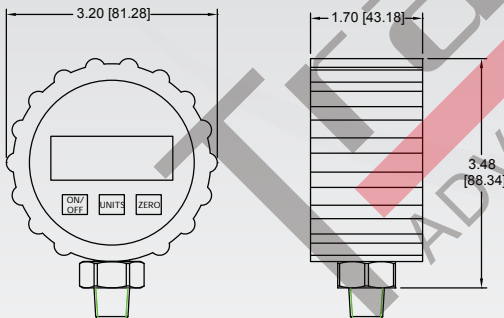

#### DIMENSIONAL DRAWING

All dimensions are in inches (mm)

#### STANDARD RANGES: (additional ranges upon request)

-15 to 30 PSI	-15 to 50 PSI	-15 to 100 PSI
0 to 500 PSI	0 to 750 PSI	0 to 1000 PSI
0 to 2500 PSI	0 to 5000 PSI	0 to 7500 PSI
0 to 10,000 PSI	0 to 20,000 PSI	0 to 40,000 PSI

**Standard configurations shown.  
Please consult factory for other options.**