

Schleifringdrehmomentsensor, rotierend
Slipring Torque Sensor, rotating

DR-12

- Nenn Drehmoment von 1 N·m ... 5000 N·m
 - Hohe Messgenauigkeit ab 0,1% v. Endwert
 - Integrierte Drehzahl-/ Drehwinkelmessung
 - Antriebs-Innenvierkant
 - Abtriebs-Außenvierkant
 - Sehr kurze axiale Baulänge
 - Hohe Drehsteifigkeit
 - Zuverlässig und robust
 - Einfache Handhabung und Montage
 - Sonderausführungen auf Anfrage
- *Nominal torque from 1 N·m ... 5000 N·m*
 - *High accuracy 0.1% f. scale*
 - *Integrated speed/ angle measurement*
 - *Drive-square socket*
 - *Output-square drive*
 - *Very short axial length*
 - *High torsional stiffness*
 - *Reliable and durable*
 - *Simple handling and assembly*
 - *Special versions on request*

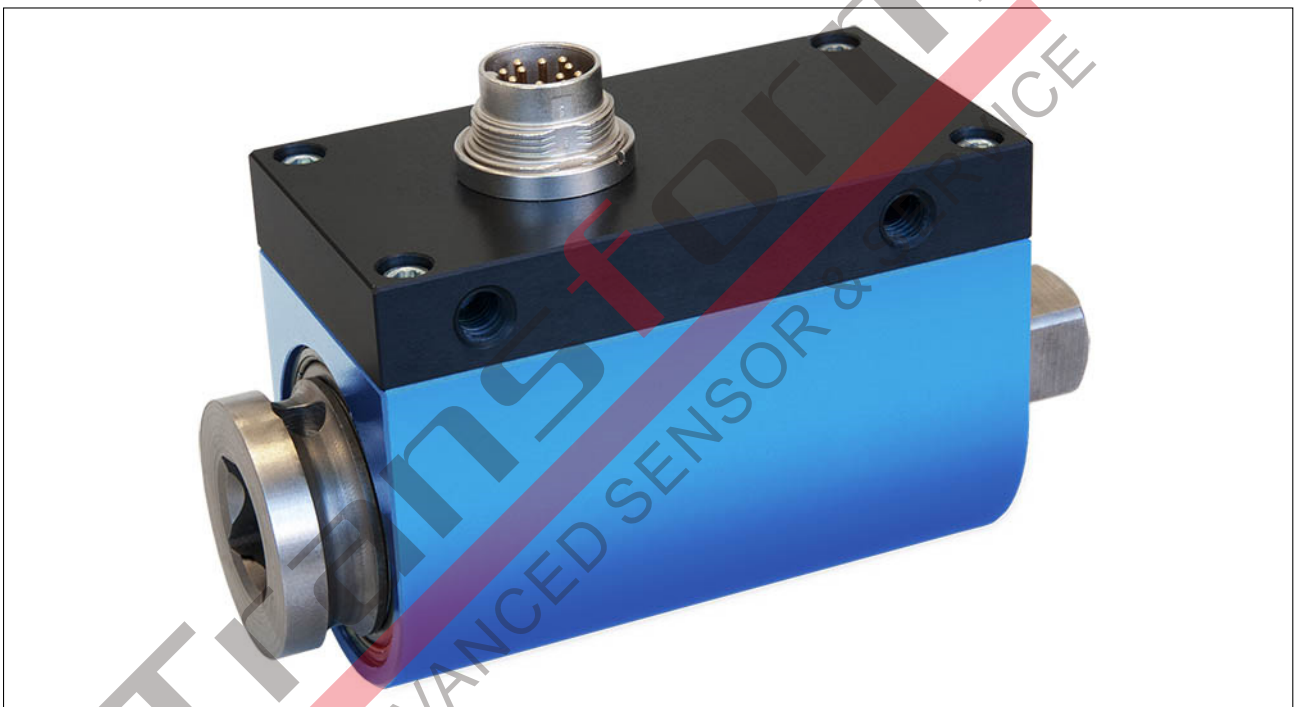

Technische Daten - Specifications

Artikel-Nr. Article-No.	Nennrehmoment Nominal Torque [N·m]	Grenzdrehzahl Limit Speed [min ⁻¹]	Federkonstante Springrate [N·m/rad]	Massen- trägheits- moment Mass Moment of Inertia [kg·m ²]		Grenzlängskraft Limit Thrust Load [N] ¹	Grenzquerkraft Limit Shear Force [N] ²
				Antriebsseite Drive Side	Messseite Test Side		
101980	1	2000	2,2E+02	3,5E-06	1,5E-06	380	5,3
101981	2	2000	2,2E+02	3,5E-06	1,5E-06	380	5,3
100212	5	2000	5,5E+02	3,5E-06	1,5E-06	690	13
101064	12	2000	6,8E+02	3,5E-06	1,5E-06	840	17
100232	25	1500	4,4E+03	1,2E-05	1,1E-05	2100	45
100233	63	1500	9,2E+03	1,2E-05	1,1E-05	3900	115
114359	100	1500	1,3E+04	1,6E-05	1,2E-05	5200	170
100234	160	1500	1,3E+04	1,6E-05	1,2E-05	5500	180
114360	200	1500	1,3E+04	1,6E-05	1,2E-05	5500	180
100235	500	1000	3,4E+04	9,0E-05	3,7E-05	10000	360
100236	1000	1000	8,7E+04	3,5E-04	1,0E-04	16200	680
100237	2000	500	3,9E+05	3,2E-03	1,2E-03	34100	1800
100238	5000	500	4,7E+05	3,3E-03	1,3E-03	46000	2750

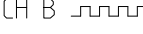
DR-12		
Genauigkeitsklasse - Accuracy class	% v. E - f. s.	0,1
Reproduzierbarkeit - Repeatability (DIN 1319)	%	±0,05
Speisespannung DMS - Excitation voltage SG	VDC	2 ... 12
Speisespannung Winkel - Excitation voltage angle	VDC	5
Brückenwiderstand - Bridge resistance	Ω	350
Nennkennwert - Nominal sensitivity	mV/V	1 [1 N·m; 0,5] ±0,1%
Referenztemperatur - Reference temperature	°C	23
Nenntemperaturbereich - Nominal temperature range	°C	5 ... 50
Gebrauchstemperaturbereich - Service temperature range	°C	-10 ... 60
Temp. koeff. des Nullsignals - Temp. coeff. of zero signal	% v. E./K - f. s./K	±0,04
Temp. koeff. des Kennwerts - Temp. coeff. of sensitivity	% v. E./K - f. s./K	±0,02
Gebrauchsdrehmoment (statisch) - Service torque (static)	% v. E - f. s.	150
Grenzdrehmoment (statisch) - Limit torque (static)	% v. E - f. s.	200
Bruchdrehmoment (statisch) - Ultimate torque (static)	% v. E - f. s.	>300
Standzeit der Bürsten ca. - Durability of brushes	Umdr. - rev.	5x10 ⁷
Schwingbreite - Bandwidth (DIN 50100)	% v. E - f. s.	70 (Spitze - Spitze) - (peak - peak)
Drehzahl-/Drehwinkelmessung, 2 x 360 Impulse, 90° versetzt, 5V TTL - Speed/angle measurement, 2 x 360 impulses, 90° displaced, 5V TTL		Rechtsdrehung - CW-turn CH A  CH B 
Schutzart - Level of protection (DIN EN 60529)		IP50
Elektrischer Anschluss - Electrical connection		12-polig Serie 581 - 12-pin series 581 ³

¹ Ungelagerte Welle - Unsupported shaft

² Ungelagerte Welle - Unsupported shaft

³ Kabeldose bei Erstausslieferung im Lieferumfang enthalten - Female cable connector in scope of delivery at first delivery

Anschlussbelegung - Pin Connection

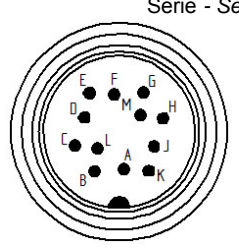
12-polig - 12-pin	DR-12	
Pin A	Speisung (-) - Excitation (-)	 <p>Serie - Series 581</p> <p>Draufsicht - Top view</p>
Pin B	Speisung (+) - Excitation (+)	
Pin C	Signal (+) - Signal (+)	
Pin D	Signal (-) - Signal (-)	
Pin E	Speisung Winkel (GND) - Excitation angle (GND)	
Pin F	Speisung Winkel (5V) - Excitation angle (5V)	
Pin G	Signal Winkel A (5V TTL) - Signal angle A (5V TTL)	
Pin H	Signal Winkel B (5V TTL) - Signal angle B (5V TTL)	
Pin J	Signal Winkel (GND) - Signal angle (GND)	
Pin K	Kontrollsignal (Option) - Control signal (option)	
Pin L	NC	
Pin M	Schirm - Shield	

Optionen/ Zubehör - Options/ Accessories

Artikel-Nr. - Article-No.	Bezeichnung - Description		
100218	Kontrollsignal - Control signal	% v. E. - f. s.	100
41382	Kabeldose 12-polig Serie 581 - Female cable connector 12-pin series 581		
45598	Winkeldose 12-polig Serie 682 - Female angled connector 12-pin series 682		
10267	Anschlusskabel, 3 m, 12-polig Serie 581, freien Lötenden - Connection cable, 3 m, 12-pin series 581, free soldered ends		
10374	Anschlusskabel winklig, 3 m, 12-polig Serie 682, freien Lötenden - Connection cable angled, 3 m, 12-pin series 682, free soldered ends		

Option Kalibrierungen - Option Calibrations

Artikel-Nr. - Article-No.	Bezeichnung - Description	Stufen - Steps	Norm - Norm
400676	Linearitätsdiagramm - Linearity diagram	25%	Werksnorm - Factory standard
400664	Linearitätsdiagramm - Linearity diagram	10%	
400961	Werkskalibrierung - Proprietary calibration	3	VDI/DE 2646
400700	Werkskalibrierung - Proprietary calibration	5	
400688	Werkskalibrierung - Proprietary calibration	8	
	DAkKS-Kalibrierung - DAkKS-Calibration		auf Anfrage - on request

Mechanische Abmessungen – Dimensions

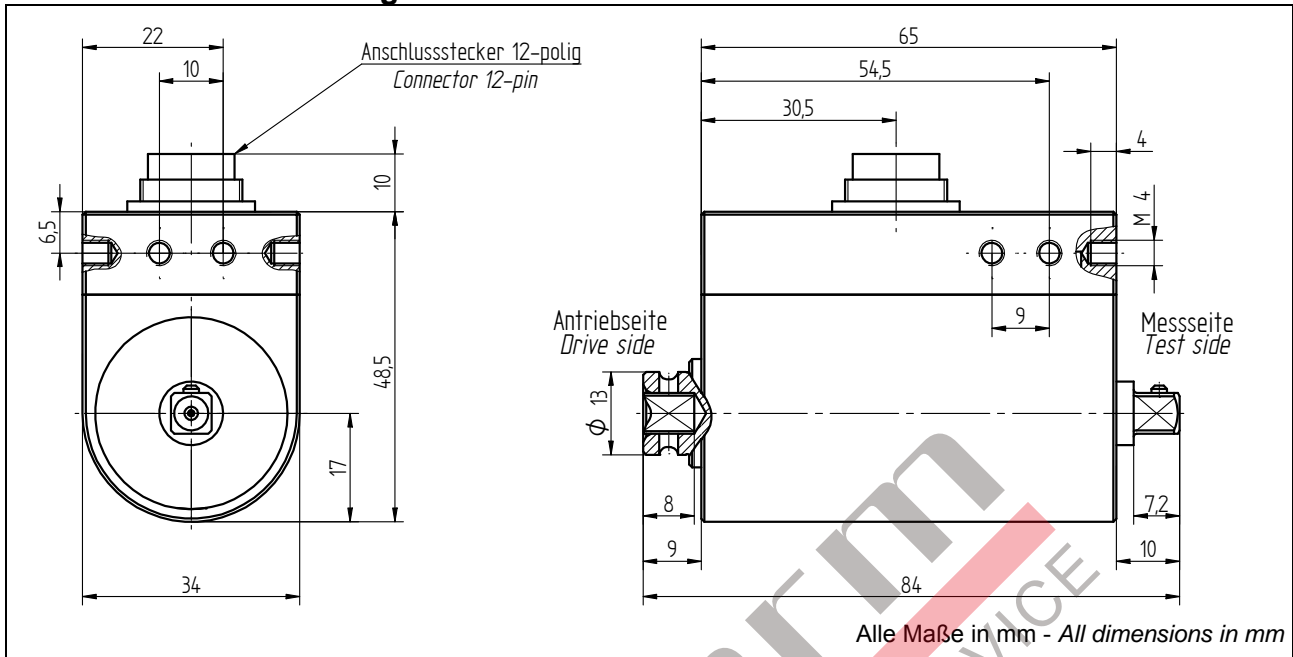

Nenn Drehmoment Nominal Torque [N·m]	Vierkant - Square 1/4"
1 / 2 / 5 / 12	

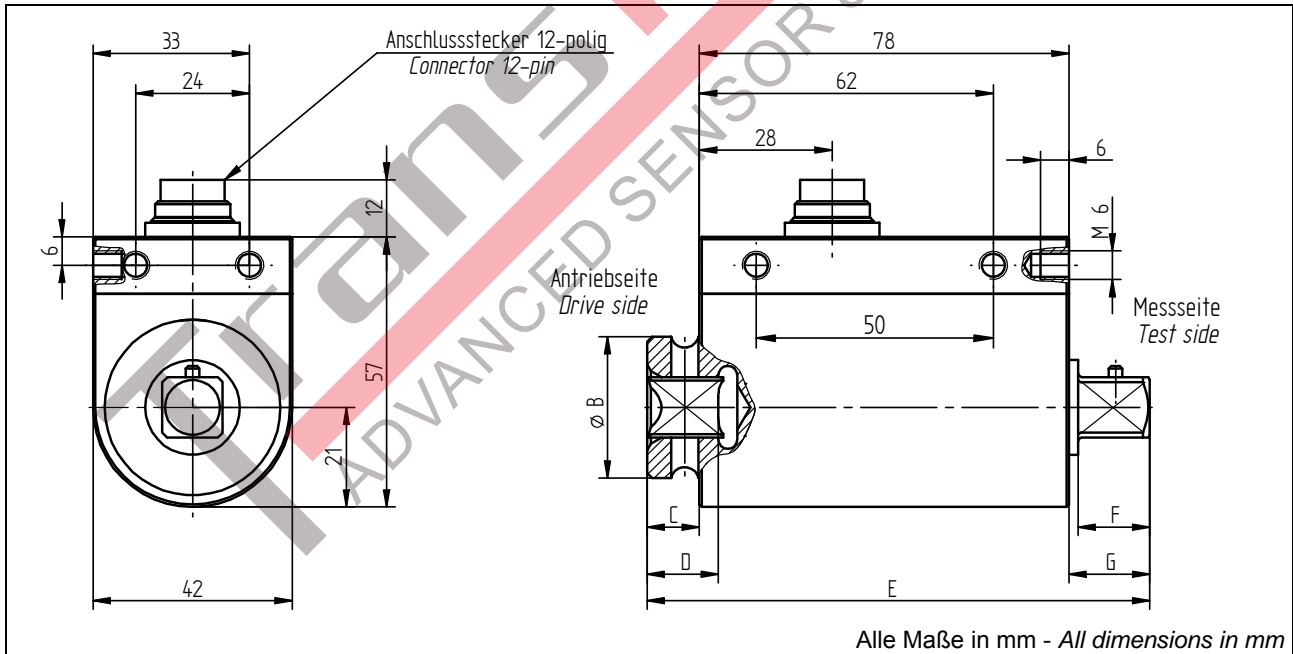

Nenn Drehmoment Nominal Torque [N·m]	Vierkant - Square	Abmessungen - Dimensions [mm]					
		B	C	D	E	F	G
25 / 63	3/8"	22	11	12,2	100,8	10,4	11,8
100 / 160 / 200	1/2"	29,8	12	15	106	15,1	16

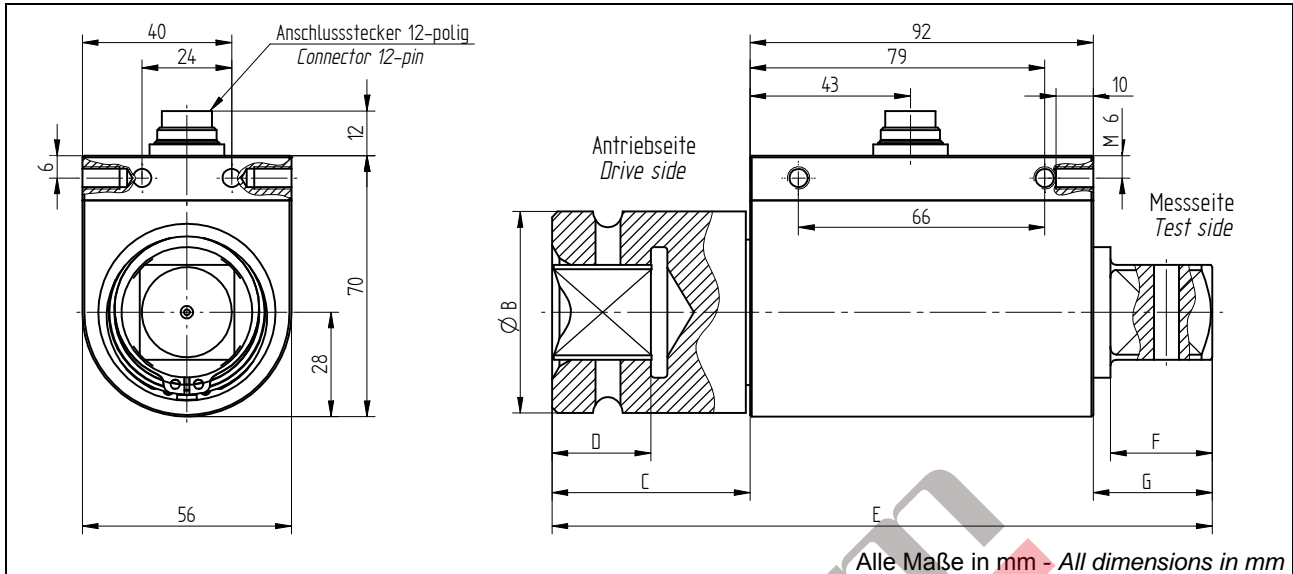

Alle Maße in mm - All dimensions in mm

Nennmoment Nominal Torque [N·m]	Vierkant - Square	Abmessungen - Dimensions [mm]					
		B	C	D	E	F	G
500	3/4"	44	18	24,9	135	22,9	25
1000	1"	54	53	29,9	177	27,4	32

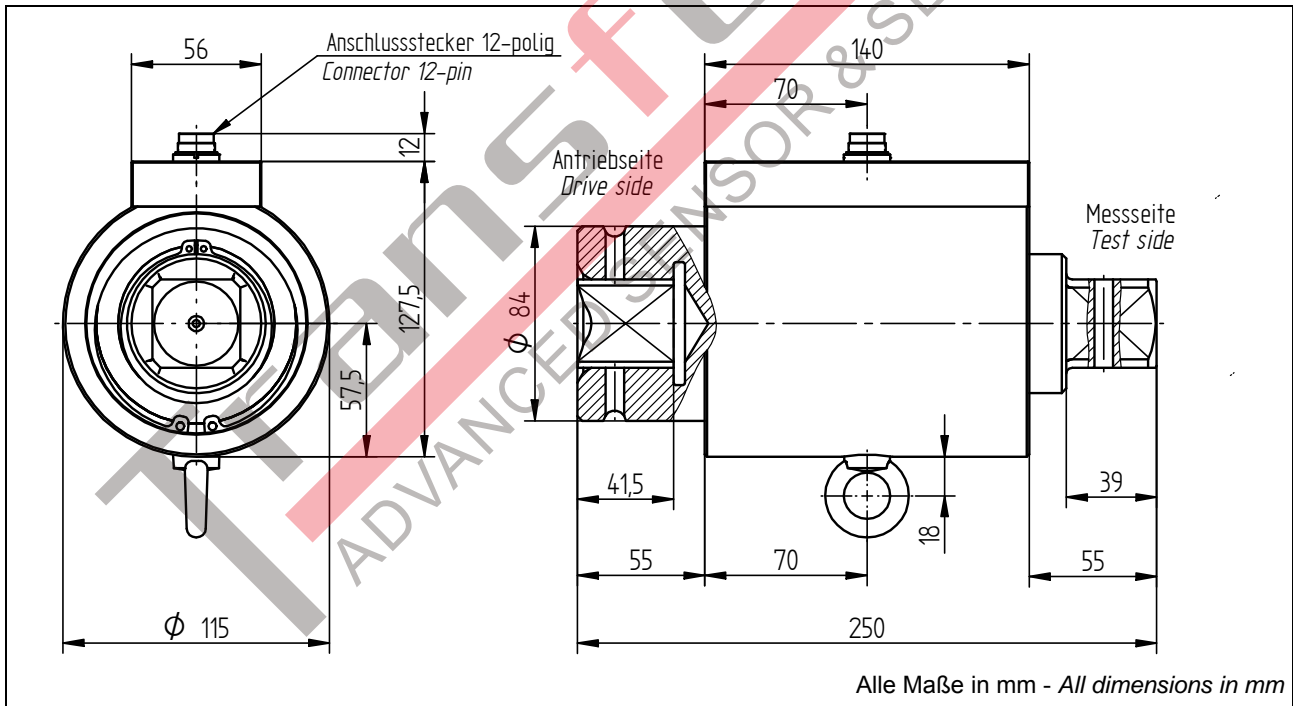

Alle Maße in mm - All dimensions in mm

Nennmoment Nominal Torque [N·m]	Vierkant - Square
2000 / 5000	1 1/2"