

**Drehmomentmessflansch, reaktiv**  
**Torque Measuring Flange, reactive**

**D-2268**

- Nenndrehmoment von 50 N·m ... 10000 N·m
  - Genauigkeitsklasse optional 0,05% v. Endwert
  - Flansch-Flansch-Lösung
  - Durchgangsbohrung
  - Sehr kurze axiale Baulänge
  - Hohe Drehsteifigkeit
  - Zuverlässig und robust
  - Einfache Handhabung und Montage
  - Sonderausführungen auf Anfrage
- *Nominal torque from 50 N·m ... 10000 N·m*
  - *Accuracy class optional 0.05% f. scale*
  - *Flange-flange-solution*
  - *Through hole*
  - *Very short axial length*
  - *High torsional stiffness*
  - *Reliable and durable*
  - *Simple handling and assembly*
  - *Special versions on request*



**Technische Daten - Specifications**

Artikel-Nr. Article-No.	Nennrehmoment Nominal Torque [N·m]	Federkonstante Springrate [N·m/rad]	Masse- trägheits- moment Mass Moment of Inertia [kg·m <sup>2</sup> ]		Grenzlängskraft Limit Thrust Load [N]	Grenzquerkraft Limit Shear Force [N]
			Antriebsseite Drive Side	Messeite Test Side		
106151	50	2,0E+05	1,1E-03	4,0E-04	600	280
102923	100	2,0E+05	1,1E-03	4,0E-04	600	280
103935	200	3,6E+05	2,5E-03	1,0E-03	920	400
103938	500	1,2E+06	7,4E-03	3,4E-03	2100	620
103939	1000	2,1E+06	7,4E-03	3,4E-03	2800	1200
103940	2000	6,2E+06	1,6E-02	9,1E-03	3800	1900
102924	5000	1,3E+07	6,5E-02	4,2E-02	6600	5200
113927	10000	2,6E+07	6,5E-02	4,2E-02	8100	9000

D-2268		
Genauigkeitsklasse - Accuracy class	% v. E - f. s.	0,1
Reproduzierbarkeit - Repeatability (DIN 1319)	%	±0,02
Speisespannung - Excitation voltage	VDC	2 ... 12
Brückenwiderstand - Bridge resistance	Ω	2000
Nennkennwert - Nominal sensitivity	mV/V	1 [≤50 N·m; 0,5] ±0,1%
Referenztemperatur - Reference temperature	°C	23
Nenntemperaturbereich - Nominal temperature range	°C	-5 ... 45
Gebrauchstemperaturbereich - Service temperature range	°C	-15 ... 55
Temp. koef. des Nullsignals - Temp. coeff. of zero signal	% v. E./K - f. s./K	±0,02
Temp. koef. des Kennwerts - Temp. coeff. of sensitivity	% v. E./K - f. s./K	±0,01
Gebrauchsdrehmoment (statisch) - Service torque (static)	% v. E - f. s.	150
Grenzdrehmoment (statisch) - Limit torque (static)	% v. E - f. s.	200
Bruchdrehmoment (statisch) - Ultimate torque (static)	% v. E - f. s.	>300
Max. dynam. Belastung - Max. dynamic load (DIN 50100)	% v. E - f. s.	70 (Spitze - Spitze) - (peak - peak)
Schutzart - Level of protection (DIN EN 60529)		IP54
Elektrischer Anschluss - Electrical connection		7-polig Serie 712 - 7-pin series 712 <sup>1</sup>

**Anschlussbelegung - Pin Connection**

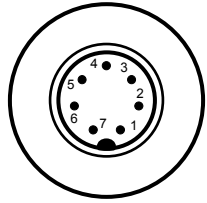
7-polig - 7-pin		D-2268
Pin 1	Speisung (-) - Excitation (-)	<div style="text-align: right;">Serie - Series 712</div>  <div style="text-align: center;">Draufsicht - Top view</div>
Pin 2	Speisung (+) - Excitation (+)	
Pin 3	Schirm - Shield	
Pin 4	Signal (+) - Signal (+)	
Pin 5	Signal (-) - Signal (-)	
Pin 6	Kontrollsignal (Option) - Control signal (option)	
Pin 7	NC	

**Optionen/ Zubehör - Options/ Accessories**

Artikel-Nr. - Article-No.	Bezeichnung - Description		
101695	Genauigkeitsklasse - Accuracy class	% v. E. - f. s.	0,05
100218	Kontrollsignal - Control signal	% v. E - f. s.	100
42828	Erweiterter Temperaturbereich - Extended temperature range		-30 °C...100 °C
42829	Erweiterter Temperaturbereich - Extended temperature range		-30 °C...120 °C
10294	Kabeldose 7-polig Serie 712 - Female cable connector 7-pin series 712		
10367	Winkeldose 7-polig Serie 712 - Female angled connector 7-pin series 712		
10316	Anschlusskabel, 3 m, 7-polig Serie 712, freien Lötenden - Connection cable, 3 m, 7-pin series 712, free soldered ends		
103348	Anschlusskabel winklig, 3 m, 7-polig Serie 712, freien Lötenden - Connection cable angled, 3 m, 7-pin series 712, free soldered ends		

**Option Kalibrierungen - Option Calibrations**

Artikel-Nr. - Article-No.	Bezeichnung - Description	Stufen - Steps	Norm - Norm
400676	Linearitätsdiagramm - Linearity diagram	25%	Werksnorm - Factory standard
400664	Linearitätsdiagramm - Linearity diagram	10%	
400961	Werkskalibrierung - Proprietary calibration	3	VDI/VDE 2646
400700	Werkskalibrierung - Proprietary calibration	5	
400688	Werkskalibrierung - Proprietary calibration	8	
	DAkKS-Kalibrierung - DAkKS-Calibration		auf Anfrage - on request

TransFOUR

ADVANCED SENSOR & SERVICE

**Mechanische Abmessungen - Dimensions**

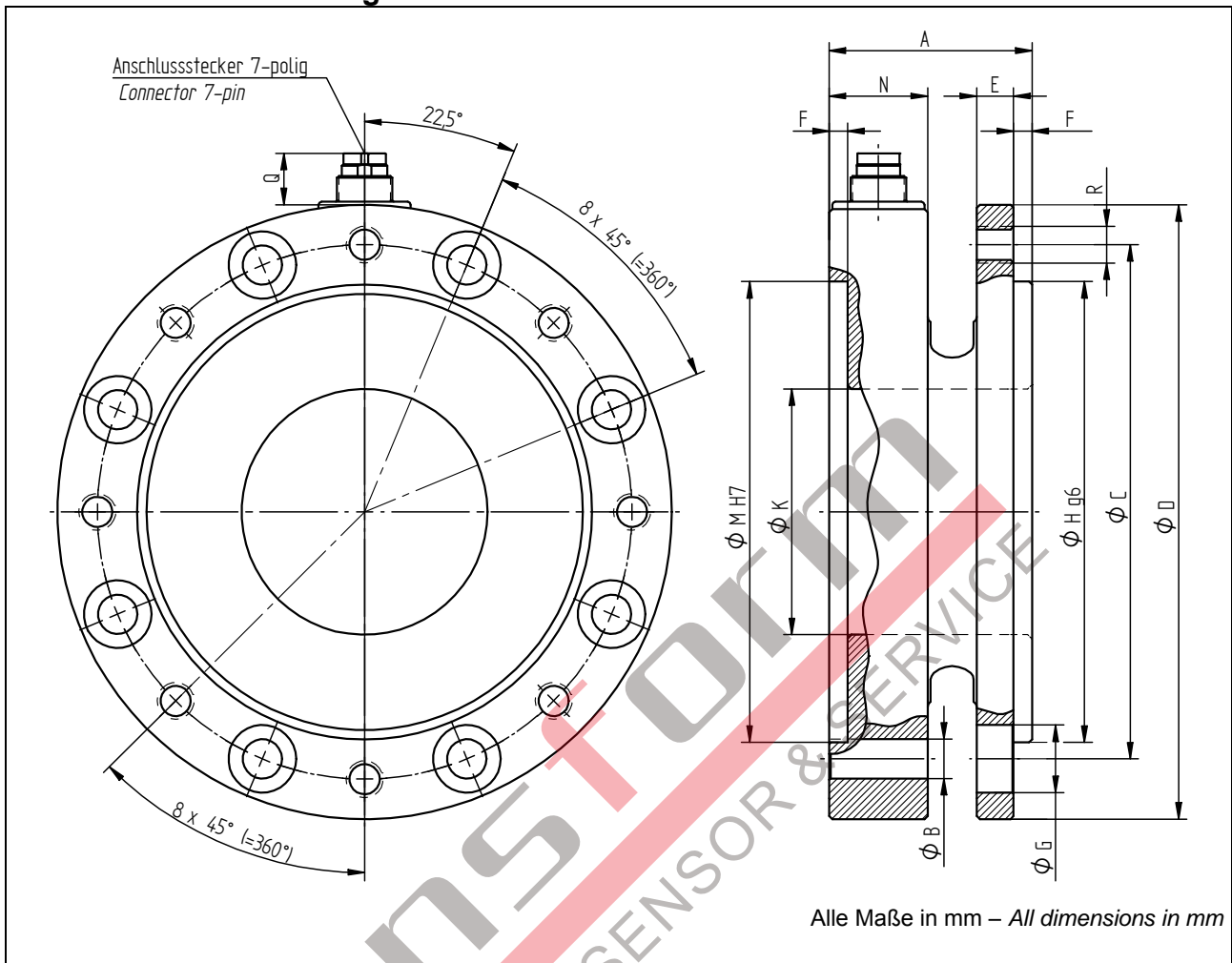

Nennmoment - Nominal Torque [N·m]	Abmessungen - Dimensions [mm]													Schraubenan- zugsmoment Tightening Torque [N·m]	Güteklasse Quality Class
	A	ØB	ØC	ØD	E	F	ØG	ØH	ØK	ØM	N	R	Q		
50 / 100	33	6,4	87	100	6	3	11	75	40	75	16	8 x M6	9	14	10.9
200	38,5	8,4	105	121	8	3	14	90	45	90	17	8 x M8	9	35	10.9
500 / 1000	43,5	13	133	156	12	3	20	110	70	110	18	8 x M12	9	120	10.9
2000	45,5	15	165	191	14	3	24	140	75	140	18	8 x M14	9	190	10.9
5000 / 10000	67	19	206	238	20	3	30	174	79	174	29	8 x M18	9	490	12.9