

Single-Column Compression Cell

FEATURES

- Capacities: 6 to 280 t
- Low profile design
- Sealing: IP66 (EN 60.529)
- Trimmed output ensures easy and accurate parallel connection of multiple load cells
- Specially designed mounting arrangements are available for vessel weighing

APPLICATIONS

- Vessels weighing
- High capacity platforms
- Tank and silo
- Process weighing

DESCRIPTION

The KSR is a sealed, single column, compression load cell. This product is suitable for high capacity platform scales and level control or process weighing in general.



A reliable sealing and mechanical protection of the strain gage area is ensured by the use of stainless steel diaphragms and a housing which are cemented to the measuring element.

OUTLINE DIMENSIONS in millimeters

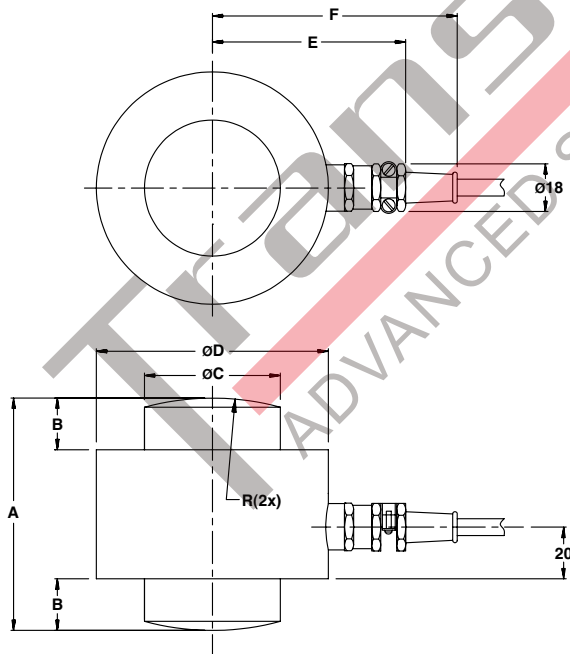

E _{max}	6	13	28	60	130	280
A	56	68	74	90	116	170
B	8	12	14	20	26	45
C	16.7	24.5	36.0	52.7	77.5	114
D	45	55	64	90	121	165
E	52.5	57.5	62.0	75.0	90.5	112.5
F	71.5	76.5	81	94	109.5	131.5
R	50	66	72	100	125	183

Cable specifications

Cable length: 10 m (6 t version: 5 m)
 Excitation + Red
 Excitation - White
 Output + Black
 Output - Blue
 Shield Transparent/Yellow
 Cable screen is not connected to the load cell body.

Single-Column Compression Cell

SPECIFICATIONS			
PARAMETER	VALUE		UNIT
Standard capacities (E_{max})	6, 13, 28, 60, 130, 280		t
Accuracy class according to type designation	Non-Approved—R2	Non-Approved—R1	
Rated output (FSO)	1.5		mV/V
Rated output tolerance	0.008		±mV/V
Zero balance	1.5		±% FSO
Combined error	0.200	0.1000	±% FSO
Minimum dead load output return	0.0700	0.0500	±% FSO
Creep error (30 minutes)	0.0800	0.0600	±% FSO
Creep error (20–30 minutes)	0.0200	0.0150	±% FSO
Temperature effect on minimum dead load output	0.025	0.025	±% FSO/5°C
Temperature effect on sensitivity	0.2500	0.2500	±% FSO/5°C
Minimum dead load	0		% E_{max}
Maximum safe overload	120		% E_{max}
Ultimate overload	300		% E_{max}
Maximum safe side load	10		% E_{max}
Deflection at E_{max}	0.35 / 0.53 / 0.80 / 1.22 / 1.85 / 2.67		mm
Excitation voltage	5 to 12		V
Maximum excitation voltage	15		V
Input resistance	275±30		Ω
Output resistance	245±0.2		Ω
Insulation resistance	≥50		MΩ
Compensated temperature range	-10 to +40		°C
Operating temperature range	-20 to +70		°C
Storage temperature range	-30 to +80		°C
Element material (DIN)	Tool steel		
Finish	Epoxy painting		
Sealing (DIN 40.050 / EN60.529)	IP66		

FSO—Full Scale Output

Mounting:

Correct mounting of the load cells is essential to ensure optimum accuracy and performance. Further information is available upon request.

All specifications subject to change without notice.

Disclaimer

ALL PRODUCTS, PRODUCT SPECIFICATIONS AND DATA ARE SUBJECT TO CHANGE WITHOUT NOTICE.

Vishay Precision Group, Inc., its affiliates, agents, and employees, and all persons acting on its or their behalf (collectively, "VPG"), disclaim any and all liability for any errors, inaccuracies or incompleteness contained herein or in any other disclosure relating to any product.

The product specifications do not expand or otherwise modify VPG's terms and conditions of purchase, including but not limited to, the warranty expressed therein.

VPG makes no warranty, representation or guarantee other than as set forth in the terms and conditions of purchase. **To the maximum extent permitted by applicable law, VPG disclaims (i) any and all liability arising out of the application or use of any product, (ii) any and all liability, including without limitation special, consequential or incidental damages, and (iii) any and all implied warranties, including warranties of fitness for particular purpose, non-infringement and merchantability.**

Information provided in datasheets and/or specifications may vary from actual results in different applications and performance may vary over time. Statements regarding the suitability of products for certain types of applications are based on VPG's knowledge of typical requirements that are often placed on VPG products. It is the customer's responsibility to validate that a particular product with the properties described in the product specification is suitable for use in a particular application. You should ensure you have the current version of the relevant information by contacting VPG prior to performing installation or use of the product, such as on our website at vpgsensors.com.

No license, express, implied, or otherwise, to any intellectual property rights is granted by this document, or by any conduct of VPG.

The products shown herein are not designed for use in life-saving or life-sustaining applications unless otherwise expressly indicated. Customers using or selling VPG products not expressly indicated for use in such applications do so entirely at their own risk and agree to fully indemnify VPG for any damages arising or resulting from such use or sale. Please contact authorized VPG personnel to obtain written terms and conditions regarding products designed for such applications.

Product names and markings noted herein may be trademarks of their respective owners.

Copyright Vishay Precision Group, Inc., 2014. All rights reserved.