

Datasheet

Torque Transducer

DRVL

Torque ranges from 0,02 to 20.000 Nm
with angle and speed measurement

Distributed by...



APPLIED MEASUREMENTS LTD.

3 Mercury House, Calleva Park, Aldermaston, Berkshire, RG7 8PN

Tel: +44 (0) 1189 817339 | Web: www.appmeas.co.uk

Fax: +44 (0) 1189 819121 | Email: info@appmeas.co.uk

NEW!



Features DRVL

- no maintenance
- contactless
- integral signal amplifier
- single supply voltage
- wide range of applications
- compact
- low moment of inertia
- speed measurement (optional)
- angle measurement (optional)
- Advanced electromagnetic compatibility (EMC)
- adjustable output level for speed- and angle signal (5 - 24 V)
- larger speed range for speed- and angle measurements
- larger input voltage range (10 - 28,8 V)
- Frequency output 10 kHz \pm 5 kHz (RS422)
- optional 0.05 % linearity error

Series DRVL torque transducers are suitable for lab and industrial applications because of their small size and multiple mounting options. As supply voltage and output signal are transmitted without contact, the device can operate continuously with low wear and no maintenance.

These transducers are also available with optional speed and angular measurement for a host of applications. The integrated signal amplifier is powered with 10 - 28,8 V DC and outputs an electrically isolated analog signals of 0 \pm 10 V and 10 kHz \pm 5 kHz. The standard version has smooth shaft ends, several types are available with optional keyways (see table).

Electrical Specifications DRVL

Supply voltage:	10 - 28,8 V DC		
Power consumption:	at Ub 12 V approx. 180 mA (switching converter 2.2 W)		
Rise time 10-90 %:	2 ms (optional 400 µs)		
Limit frequency -3 dB:	200 Hz (optional 1 kHz)		
	Voltage output:	Output frequency:	
Voltage output:	0 ± 10 V	10 kHz ± 5 kHz (RS422)	
Resolution:	16 bit ± 0,38 mV	16 bit ± 0,19 mHz	
Max. output range:	± 11 V	± 6,3 KHz	
Internal resistance:	100 Ω	–	
Ripple:	< 100 mVss	–	
Nonlinearity/max. measurement error (of full scale)			
DRVL:	0,15 % (optional 0,1 %)	0,15 % (optional 0,1 %)	
DRVL-I to DRVL-VI:	0,1 % (optional 0,05 %)	0,1 % (optional 0,05 %)	
Hysteresis	0,1 %	0,1 %	
Deviation at zero point:	≤ 50 mV	≤ 50 Hz	
Operating temperature:	0 - 60 °C		
Compensated temperature range:	5 - 45 °C		
Temperature error			
Zero point:	0,02 % / K		
Sensitivity:	0,01 % / K		
Mechanical overload:	100 %		
Internal protection:	IP 40 (DIN 40050)		
Connection:	12pin-connector		
Interference emission			
Basic standard	Frequency range		
EN55011 Limit class B	150 kHz - 6 GHz		
Immunity to interference			
Basic standard	Testing accuracy	coupling	Result
EN61000-4-2:2009 Electrostatic discharge (ESD)	4 kV	direct	A
EN61000-4-2:2009 Electrostatic discharge (ESD)	4 kV	indirect	A
EN61000-4-3:2009 Electromagnetic fields	10 V/m	indirect	A
EN61000-4-4:2009 Bursts	2 kV	indirect	A
EN61000-4-5:2005 Surge voltages	1 kV	direct	B
EN61000-4-6:2009 Conductor-borne RF disturbances	10 V/m	indirect	A
EN61000-4-8:2005 Power frequency magnetic fields	30 A/m	indirect	A
A: Deviation of outputs during the test < 0.3 % of full scale			
B: Deviation of outputs during the test > 0.3 % of full scale			

	Speed Option (n)	Angle Option (w)
max rev.:	≤ 37.000 1/min*	≤ 20.000 1/min*
Output:	TTL or over voltage on pin 5 V < U < 24 V	
Impedance:	22 Ω	22 Ω
I _{max} :	20 mA	20 mA
Pulses/rev.:	60	2 x 360
Resolution:	--	1°
Phase shift:	--	Channel A 90° at right spin of propulsion side

* The values are valid for ETH test cables ≤ 10 m, the maximum permissible speed of the sensor must be observed.

Mechanical Dimensions DRVL

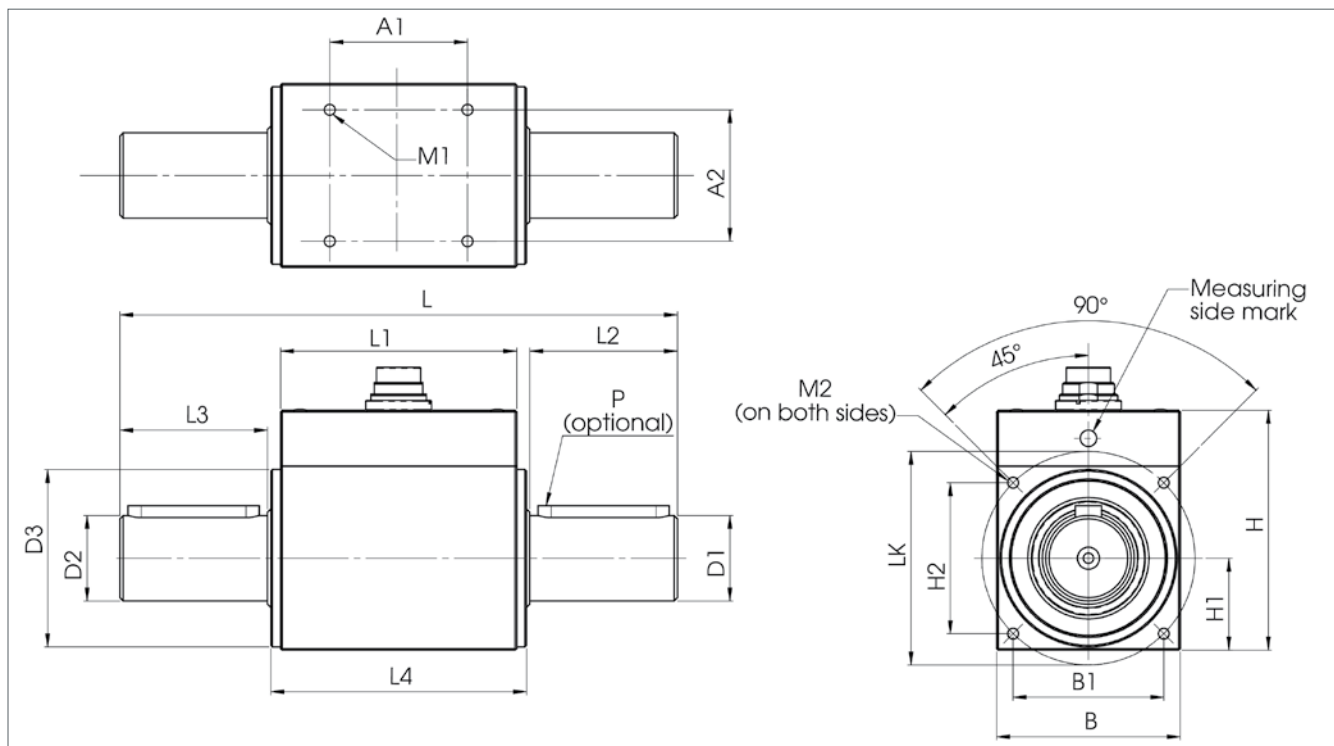

Model	DRVL	DRVL-I	DRVL-Ib	DRVL-II	DRVL-III	DRVL-IV	DRVL-V	DVFL-VI	
Torque Ranges (Nm)	0,02 0,05 0,1	0,05 0,1 0,2 0,5 1	2	1 2 5 10	5 10 20 30 50	50 100 150 200 300	500 1000 1300 1500	2000 3000 4000 5000	10.000 15.000 20.000
Dimensions: (other ranges upon request; General tolerances DIN 2768-m)									
L (mm)	82	89	95	110	145	170	270	320	355
B (mm)	32	28		36	42	56	88	105	168
B1 (mm)	24	→ LK		→ LK	→ LK	→ LK	→ LK	→ LK	--
H (mm)	47	54		58	58	73	104	121	185
H1 (mm)	14	14		18	21	28	44	52,5	84
H2 (mm)	22	→ LK		→ LK	→ LK	→ LK	→ LK	→ LK	--
∅ D1 g6 (mm)	3	8	8	10	15	26	45	70	110
∅ D2 g6 (mm)	3	5	6	10	15	26	45	70	110
∅ D3-0,1 (mm)	15	27		32	38	54	80	--	--
∅ LK ± 0,1 (mm)	→ B1/H2	32		38	46	65	98	--	--
L1	63	62		68	79	72	84	95	121
L2	7,5	10	14	18	30	45	85	110	115
L3	7,5	11	14	18	30	45	85	110	115
L4	67	66		72	83	78	90	--	--
A1	50	40		56	60	42	46	75	91
A2	24	22		24	32	40	70	85	138
M1	M2,5 x 5 deep	M3 x 5 deep	M3 x 6 deep	M3 x 6 deep	M4 x 8 deep	M6 x 12 deep	M8 x 16 deep	M10 x 16 deep	
M2	M2,5 x 5 deep	M3 x 6 deep	M3 x 6 deep	M3 x 6 deep	M4 x 8 deep	M6 x 12 deep	--	--	
P (DIN 6885) optional	--	--	2xA3x3x14	2xA5x5x25	2xA8x7x40	4xA14x9x80	4xA20x12x100	--	
Weight (g)	200	170		340	600	1300	4500	11.500	33.000
n max (1/min)	20.000	37.000		26.000	19.000	13.500	7900	6300	4000

Technical Specifications DRVL

Model	Torque range (Nm)	Spring constant C (Nm/rad)	Mass moment of inertia J (g x cm ²)	Rated axial load (N) *	Rated radial load (N) *
DRVL	0,02	16	7	35	30
	0,05	16	7	35	30
	0,1	16	7	35	30
DRVL-I	0,05	20	10	105	2
	0,1	35	10	140	3
	0,2	35	10	140	3
	0,5	45	10	160	4
	1	90	10	210	7
	2	135	10	210	13
DRVL-Ib	1	255	30	630	10
	2	255	30	630	10
	5	715	30	725	25
	10	1320	30	725	50
DRVL-II	5	960	100	1200	15
	10	2115	100	1300	30
	20	3955	100	1300	60
	30	5340	105	1300	100
	50	6700	105	1300	155
DRVL-III	50	17 x 10 ³	775	1800	125
	100	30 x 10 ³	785	1800	215
	150	45 x 10 ³	800	1800	340
	200	54 x 10 ³	810	1800	450
	300	67 x 10 ³	840	1800	650
DRVL-IV	500	260 x 10 ³	9935	4150	650
	1000	387 x 10 ³	10.140	4150	1275
	1300	429 x 10 ³	10.285	4150	1650
	1500	449 x 10 ³	10.380	4150	1700
DRVL-V	2000	1,45 x 10 ⁶	63 x 10 ³	4800	1950
	3000	1,85 x 10 ⁶	64 x 10 ³	4800	2930
	4000	2,10 x 10 ⁶	64 x 10 ³	4800	3880
	5000	2,30 x 10 ⁶	65 x 10 ³	4800	4000
DRVL-VI	10.000	8,20 x 10 ⁶	440 x 10 ³	11.800	8895
	15.000	10,45 x 10 ⁶	448 x 10 ³	11.800	9830
	20.000	11,80 x 10 ⁶	546 x 10 ³	11.800	9830

* The values for axial and radial load apply to the non-fixed case

Ordering code system

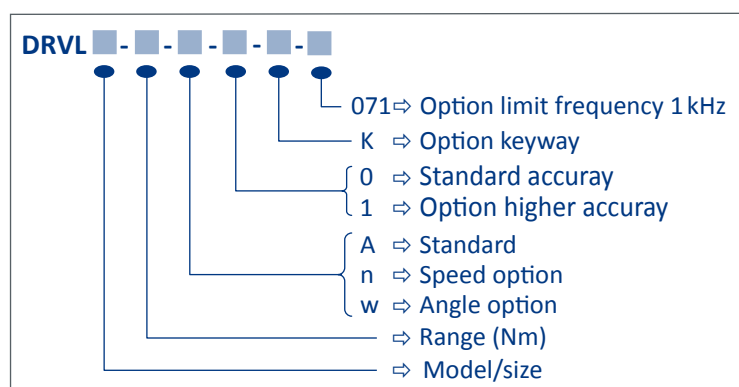

Available Accessories

Supply and display unit: GMV2
ValueMasterBase

Cables
Couplings

Distributed by...



APPLIED MEASUREMENTS LTD.

3 Mercury House, Calleva Park, Aldermaston, Berkshire, RG7 8PN
Tel: +44 (0) 1189 817339 | Web: www.appmeas.co.uk
Fax: +44 (0) 1189 819121 | Email: info@appmeas.co.uk