

SP SERIES WHEEL SPEED SENSOR



The SP Series of Wheel Speed Sensors have been designed as simple compact sensors suited to the demanding motorsport and automotive testing industries.

The main construction is stainless steel with a maximum operating temperature of 150°C, which provides for a robust sensor even in exposed areas such as the engine bay or wheel hub.

By using a proven 'Hall Effect' sensing technology, the SP detects a change in magnetic field as the target passes the sensors tip. The output transistor switches its state as the target passes, so giving a measurable pulse train which can be used within standard data logging equipment or ECU's.

TECHNICAL SPECIFICATIONS

Measurement Frequency	8KHz
Sensor Type	Hall Effect
Mounting	M12 x 1.25 or 7/16-20UNF-2A Thread, 2x Lock Nuts
Sensing Range (Air Gap)	2 to 3mm
Target Size (Width x Length)	8mm Wide x 1mm Long (Minimum)
Output	NPN. Internal Pullup Resistor Value 10KΩ
Max Load Current	25mA Max
Supply	5-24Vdc (10mA)
Operating Temperature Range	-40°C to +150°C
Construction	303 Grade Stainless Steel
Electrical Connection	50cm 22AWG 55Spec Cable + DR25 Sleeve
Thread Dimensions	Please See Mechanical Drawings
Protection Class	IP67
EMC Protection	EN 560947-5-2
Weight (Excluding Cable)	25g
Options	Cable Specifications and Labelling

KA Sensors adopts a continuous development program which sometimes necessitates specification changes without notice.

Sensors For Motorsport

Features

- Miniature Size
- M12 or 7/16 Mounting
- NPN Output
- 5-24V Supply
- IP67 Sealed
- High Temperature

Applications

- Drive Shaft Speed
- Traction Control
- Launch Control
- Wheel Speed

kasensors.com

sales@kasensors.com

+44(0)1476 568057

SP12 10.18

PART NUMBER CONFIGURATOR

Thread Size

7/16-20 UNF-2A Male
M12 x 1.25 Male

Output

NPN. Internal Pullup Resistor Value 10K Ω

Thread Length

40mm Long

Cable Length

50cm 22AWG 55Spec Cable + DR25 Sleeve

Special Code

None

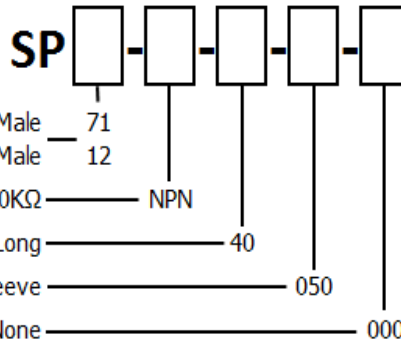

The KA configuration tool is used to specify a standard KA Sensor, other options are available.

MECHANICAL DETAILS

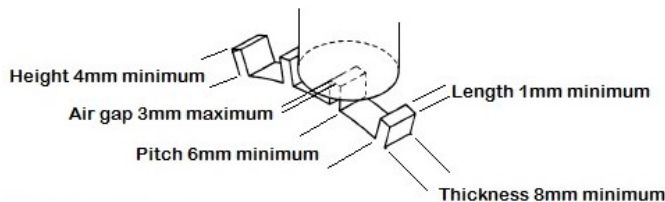
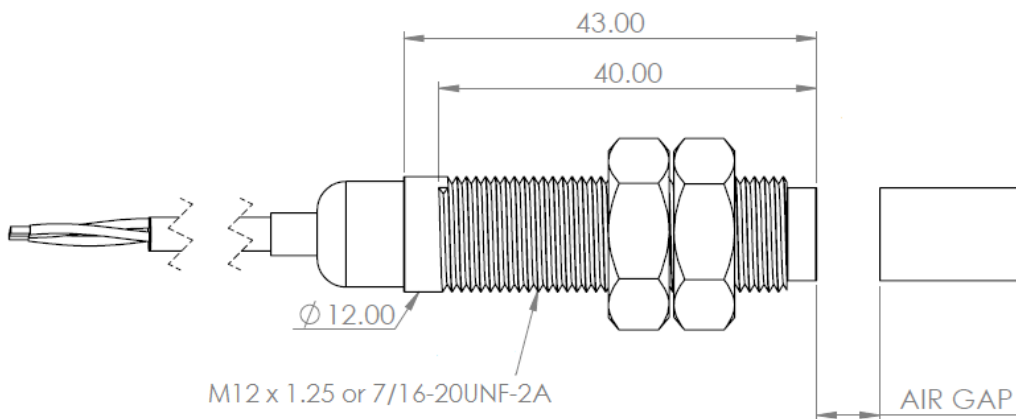

CONNECTION DETAILS

+Ve Supply	0V Supply	Signal
Red	Black	White

*Sense
Analyse
Control*

Services for:

- Data Logging
- Telemetry
- Controls
- Wiring

Contact us

KA Sensors Ltd
Unit 14 & 15
The Old Malthouse
Springfield Road
Grantham
Lincolnshire
United Kingdom
NG31 7BG

kasensors.com
sales@kasensors.com
+44(0)1476 568057

SP12 10.18