

KAT SERIES DUAL & TRIAXIAL ACCELEROMETER

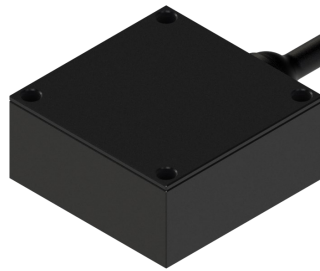

The KAT Series of Accelerometers offer a compact and robust solution for the measurement of true inertial data in the motorsports and automotive testing industry.

The sensor offers 3 Axis of measurement with integral signal conditioning to give a standard signal of 0.5 to 4.5V; ideal for most data acquisition systems.

Supply voltage can be 5V or 8-16V with low current consumption of less than 35mA.

The use of low bandwidth sensing elements ensures that high frequency vibration from transmission components or similar do not effect the measurements.

Different ranges can be fitted to each axis, full customisation is possible to suit complex applications.

TECHNICAL SPECIFICATIONS

Range (g)	Standard Ranges: 2, 5, 7.5 and 10
Bandwidth	20Hz
Resonant Frequency	5kHz
Safe Over Range	±20,000g
Accuracy	<±1% FS Linearity
Cross Axis Sensitivity	<±1% FS
Thermal Effects	Zero ±0.015% FS/°C (Sensitivity ±0.015% of Reading /°C)
Output	0.5V to 4.5V (Offset 2.5V)
Supply	5V (±0.5V) Ratiometric or 8-16Vdc
Operating Temperature Range	-20°C to +100°C
Compensated Temperature Range	20°C to +100°C
Noise	>1mg√Hz
Construction	Anodised Aluminium
Electrical Connection	50cm or 100cm, 55Spec, 26AWG Cable + DR25 Sleeve
Protection Class	IP66
EMC Protection	EN 50082-1
Weight	30g (Excluding Cable)
Options	Connector Fitted and Part Number Labelling

KASensors adopts a continuous development program which sometimes necessitates specification changes without notice.

Sensors For Motorsport

Features

- Miniature Size
- ±2g to ±10g
- 3 Axis Outputs
- 0 to 20Hz Bandwidth
- ±20,000g Over Range
- Built-In Amplifier

Applications

- Aero Performance
- Launch Control
- Track Mapping
- Lean Angle
- Cornering
- Braking

kasensors.com

sales@kasensors.com

+44(0)1476 568057

KAT 10.18

PART NUMBER CONFIGURATOR

Range ($\pm g$)

Supply

Number of Axis

Cable Length

Special Code

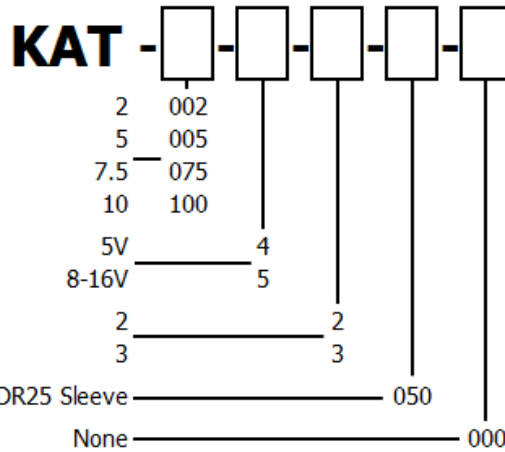

50cm, 55Spec, 26AWG Cable+DR25 Sleeve

None

The KA configuration tool is used to specify a standard KA Sensor, other options are available.

MECHANICAL DETAILS

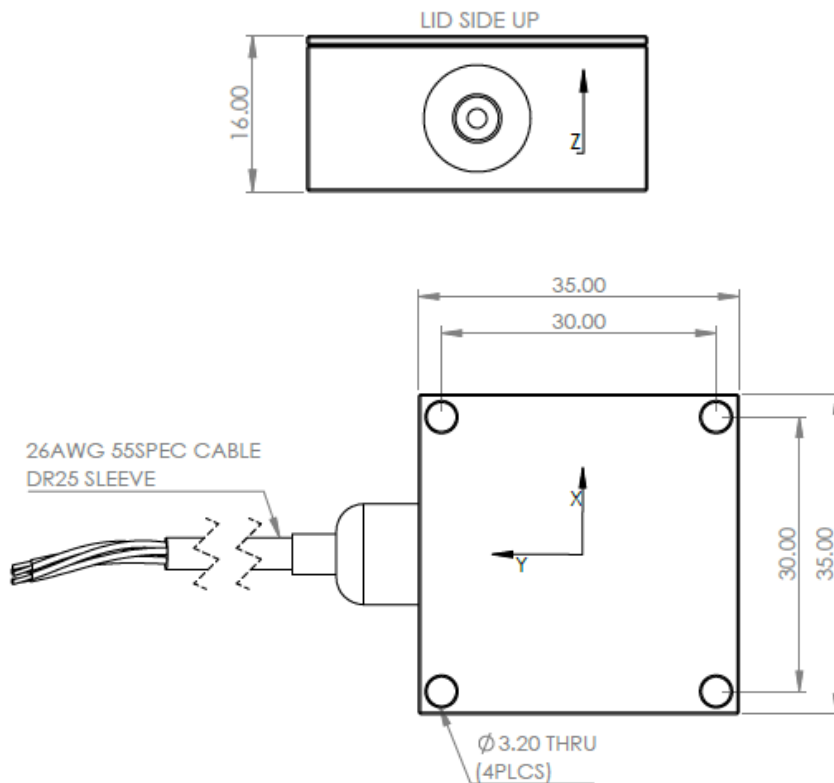

CONNECTION DETAILS

+Ve Supply	0V Supply	Output (X)	Output (Y)	Output (Z)
Red	Black	White	Blue	Green

*Sense
Analyse
Control*

Services for:

- Data Logging
- Telemetry
- Controls
- Wiring

Contact us

KA Sensors Ltd
Unit 14 & 15
The Old Malthouse
Springfield Road
Grantham
Lincolnshire
United Kingdom
NG31 7BG

kasensors.com
sales@kasensors.com
+44(0)1476 568057

KAT 10.18