

M40H Torque Transducer



The M40H is a digital torque transducer for measuring torque at the range from ± 3 to ± 6 kNm, at the rotating speed up to 4 000 rpm.

The transducer consists of two components: a rotor and a stator and is designed without bearings and without slip-rings. The special feature is the through the hole $\varnothing 100$ mm along the spin axis. Due to special rotor construction, you benefit high permissible bending moment and transverse forces. The M40H torque transducers are equipped with the advanced digital telemetry system for contactless transmission of the measured torque data from the rotor to the stator.

This digital coded signal has high interference immunity, provides high accuracy of measurements and can be transmitted over significant distances without distortion and loss of information.

The stator has the divisible construction and is easy to mount on a test bench.

The torque output signal is digital (RS232, RS485 (Modbus RTU protocol), USB 2.0 interfaces),

analogue (± 5 V, ± 10 V, 4 ... 20 mA) and frequency (10 kHz \pm 5 kHz, 60 kHz \pm 30 kHz). M40H can be easily connected to a PC. The Windows-based software for data acquisition and its processing is included in the scope of supply with the M40H torque transducer.

The M40H transducers have a built-in optoelectronic speed sensor.

As there are no bearings and no slip-rings friction losses and heating will not occur. The M40H torque transducers are easy to mount and maintenance-free.

M40H torque transducers are suitable to determine static as well dynamic rapidly changing torque in positive and negative polarity

Type-Survey

Type	Nominal torque, Nm			Max. speed, rpm
M40H-3k ... 6k	3 000	5 000	6 000	4 000

M40H Stator. Dimensions in mm

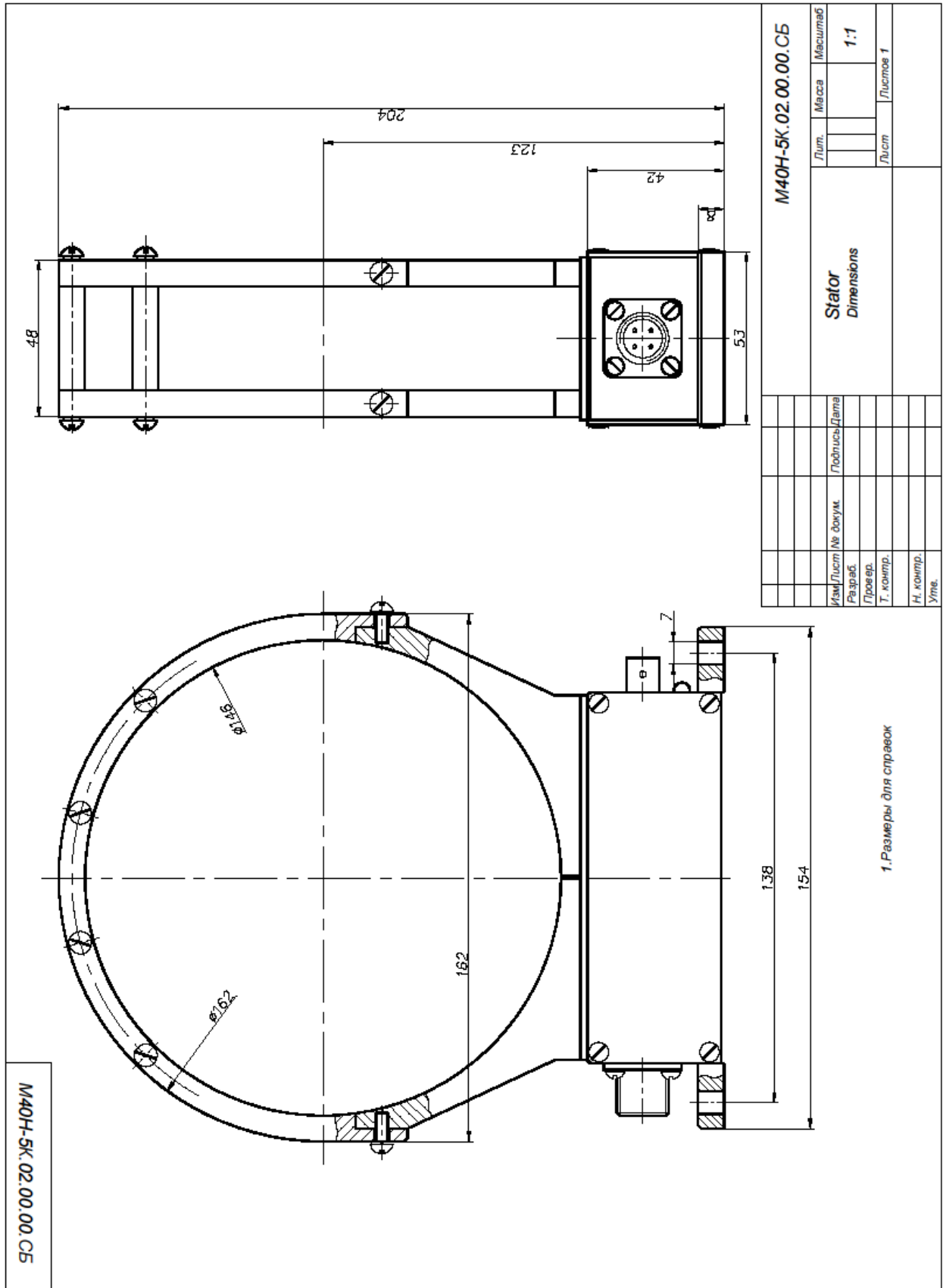

Изм/Лист		№ докум.	Подпись/Дата
Разраб.			
Провер.			
Т. контр.			
Н. контр.			
Утв.			

M40H-5K.02.00.00.C5	
Лист	Масса
Лист	Масштаб
Лист	1:1
Лист	Листов 1

Stator Dimensions

M40H Rotor. Dimensions in mm

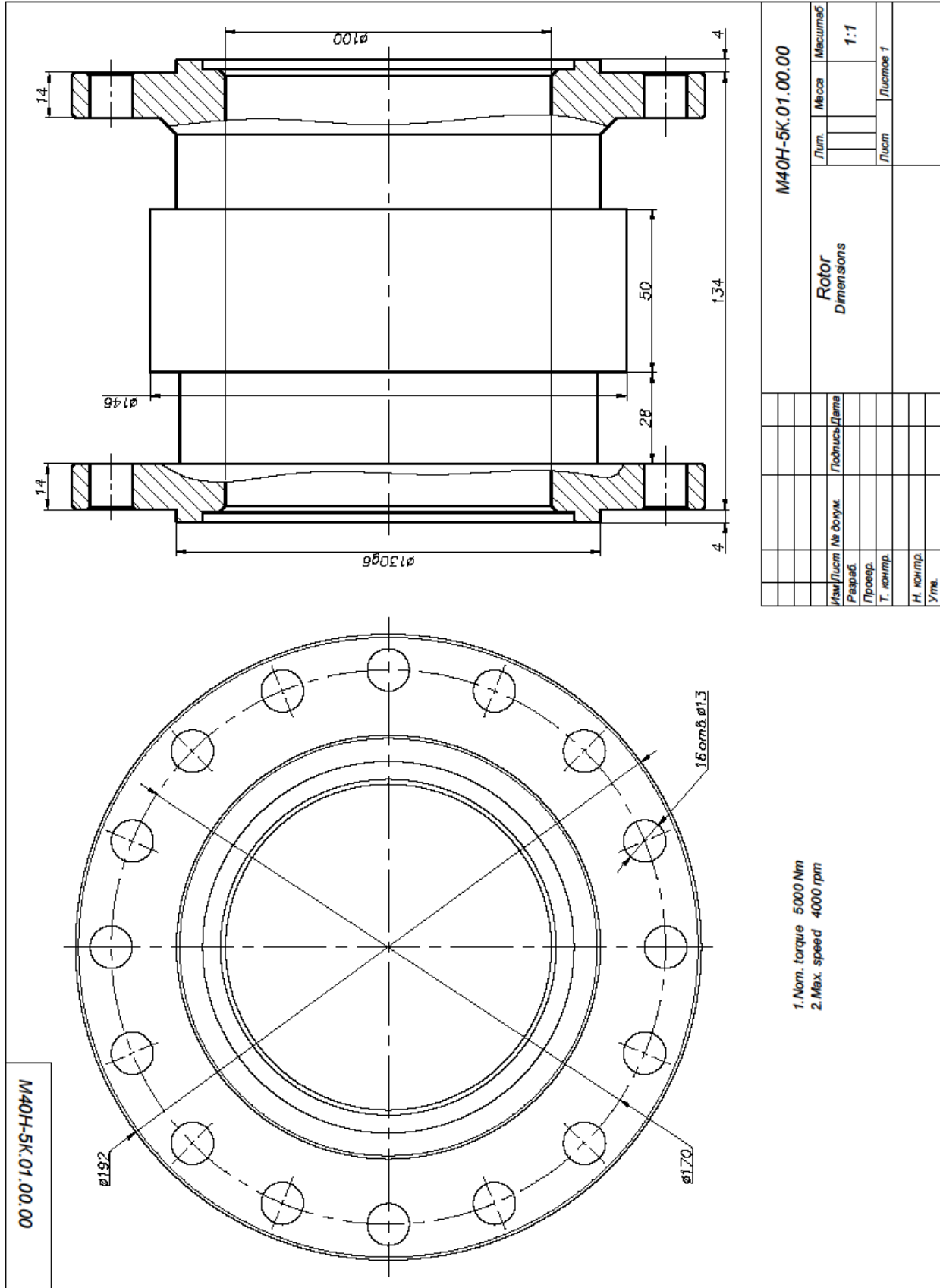

Technical data

Nominal torque M_N and max. speed see table «Type-Survey».

Accuracy class		0.2
Deviation of the actual output signal at the nominal torque from the nominal value (including hysteresis and nonlinearity)	%	± 0.2
Temperature effect per 10 °C on the zero signal, related to the nominal output value	%	± 0.1
Nominal supply voltage	V (DC)	12 ... 30
Power consumption	W	< 5
Measurement frequency range	Hz	0 ... 1 000 (- 1.5 dB)
Amplitude ripple (0 ... 500 Hz)	dB	≤ 0.1
Frequency output (T23 decoder)		
Frequency output signal with positive nominal torque	kHz	15 (90)
Frequency output signal with negative nominal torque	kHz	5 (30)
Frequency output signal at torque = zero	kHz	10 (60)
Load resistance	kΩ	≥ 2
Output voltage	V	5 ± 1 (symmetrical meander)
Input-output galvanic isolation		+
Analogue output (T24 decoder)		
Nominal output signal with positive (right-hand) nominal torque	V	+ 5 (+ 10)
Nominal output signal with negative (left-hand) nominal torque	V	- 5 (- 10)
Output signal at torque = zero	V	0
Load resistance	kΩ	≥ 10
Analogue output (T24/4 ... 20 mA decoder)		
Output current	mA	4 ... 20
Output current at loading = zero	mA	12
Output current at nominal positive loading	mA	20
Output current at nominal negative loading	mA	4
Load resistance	kΩ	≥ 100
Digital output (T45 decoder)		
Interface		USB 2.0
Data transfer rate (Full-Speed)	Mbit/sec	12
Sample rate	kSample	5.0
Input-output galvanic isolation		+
Digital output (T37 decoder)		
Interface		Ethernet
Data transfer rate	Mbit/sec	10; 100
Sample rate	kSample	5.0
Input-output galvanic isolation		+
Digital output (T46 decoder)		
Interface		RS485
Protocol		MODBUS RTU
Data transfer rate	baud	2 400 - 115 200
Parity check		+
Sample rate	kSample	5.0
Input-output galvanic isolation		+
Digital output (T42 decoder)		
Interface		RS232
Data transfer rate	baud	2 400 - 115 200
Parity check		+
Sample rate	kSample	5.0
Input-output galvanic isolation		+
Rotation speed measuring system		
Accuracy (within 30 ... 20 000 rpm)	%	±0.1
Pulses per revolution depending on a decoder	T23, T24	1
	T23/3, T24/3	60, 120, 360, 480, 720 (optionally)
Min. detected speed	rpm	30
Amplitude of output pulse voltage with analogue (frequency) output	V	5±1

Parameters of resistance to environment and mechanical exposures

Nominal temperature range	°C	0 ... + 60
Humidity	%	95 (35 °C)
Atmospheric pressure	kPa	84 ... 106.7 (630 ... 800 mm Hg)
Storage temperature range	°C	- 10 ... + 70
Storage humidity	%	95 (+ 30 °C)
Vibration resistance:		
Frequency range	Hz	10 ... 55
Duration	h	1
Acceleration	m/s ²	40
Impact resistance:		
Number of impacts	n	1 000
Duration	ms	10
Acceleration	m/s ²	400
Degree of protection		IP40

Permissible load limits and mechanical values

Nominal torque M _N	Nm	5 000
Axial limit force on the rotor	kN	20
Lateral limit force on the rotor	N	5 000
Bending limit moment on the rotor	Nm	500
Torsional stiffness	kNm/rad (kNm/deg.)	7 500 (41.7)
Weight: rotor	kg	7.6
stator		1.0

Axial force, radial force and bending moment have to be reduced according to graph 1, if they act together. To prevent from excessive stress due to misalignment and thermal influences the transducer should be fitted between flexible couplings. We offer such flexible torsionally rigid couplings MK series. Technical specification see in the data sheet entitled "MK Couplings".

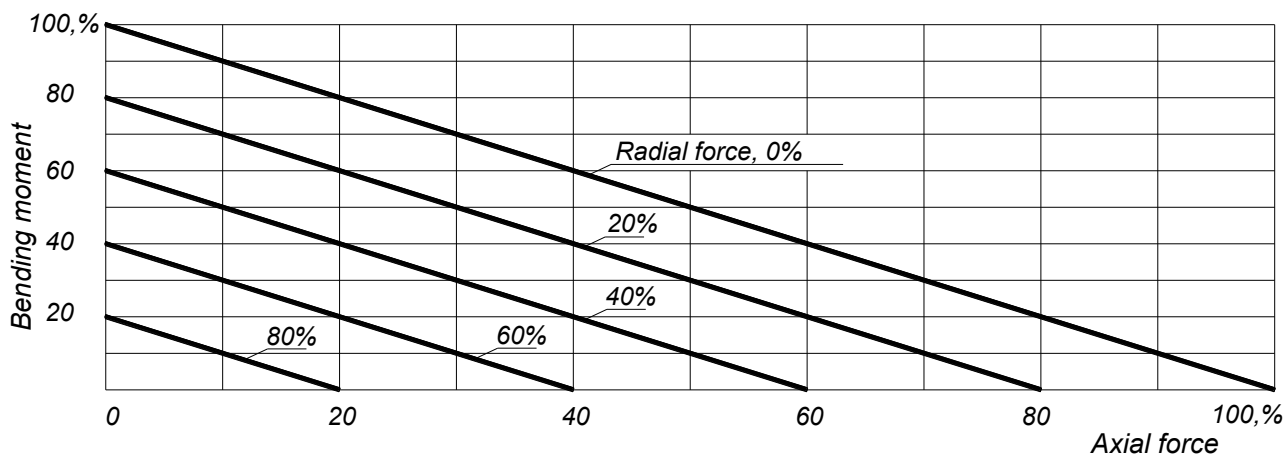

Scope of supply

M40H Rotor	1
M40H Stator	1
Txx decoder	1
Output signal cable, 5 m long (optionally can be over in length)	1
Output signal cable, 2 m long	-
Power supply connector 2PM14	1
"Transducer" software for Windows XP, 7, 8, 10 OS	1
Software user manual	1
Operating manual	1

Accessories (to be ordered separately and optionally)

MK flexible torsionally rigid couplings	2
T40 display unit (displaying of torque, rotating speed, power)	1
T41 display unit (plastic case)	1
T50 display unit (for long distances)	1
T24 analogue decoder (output ± 5 V, ± 10 V or 4 ... 20 mA)	1
T23 frequency decoder (output 10 ± 5 kHz or 60 ± 30 kHz)	1
T45 digital decoder (USB 2.0)	1
T42 digital decoder (RS232)	1
T46 digital decoder (RS485)	1
T37 digital decoder (Ethernet)	1
AC/DC adapter (12 ... 30 V)	1

T42, T45, T46 digital decoders. Dimensions in mm.

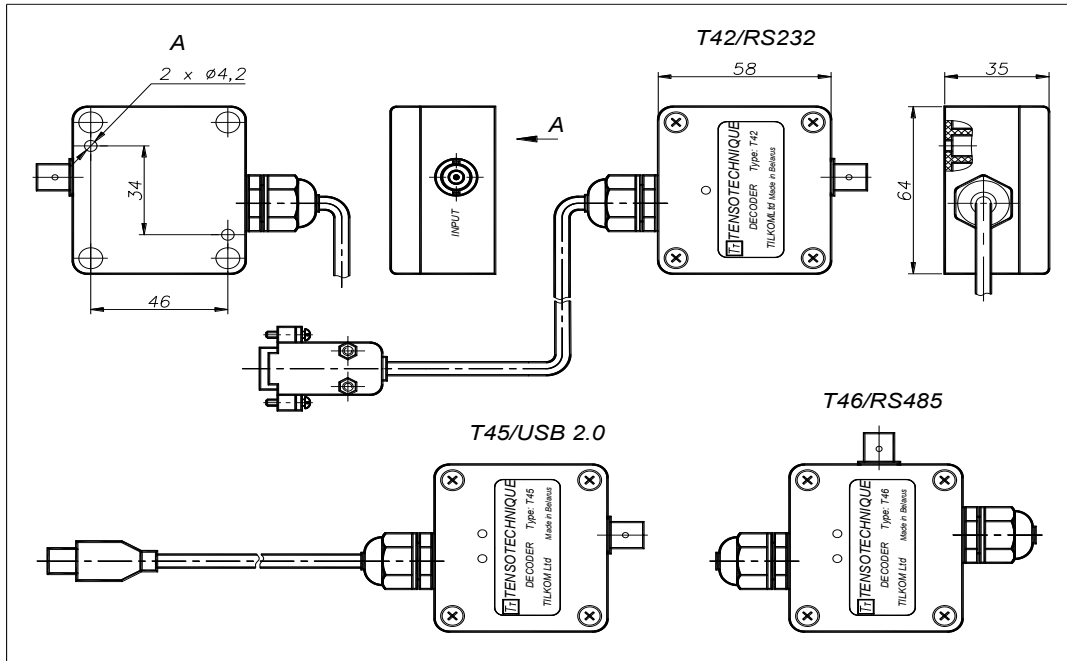

T24 analogue decoder. Dimensions in mm.

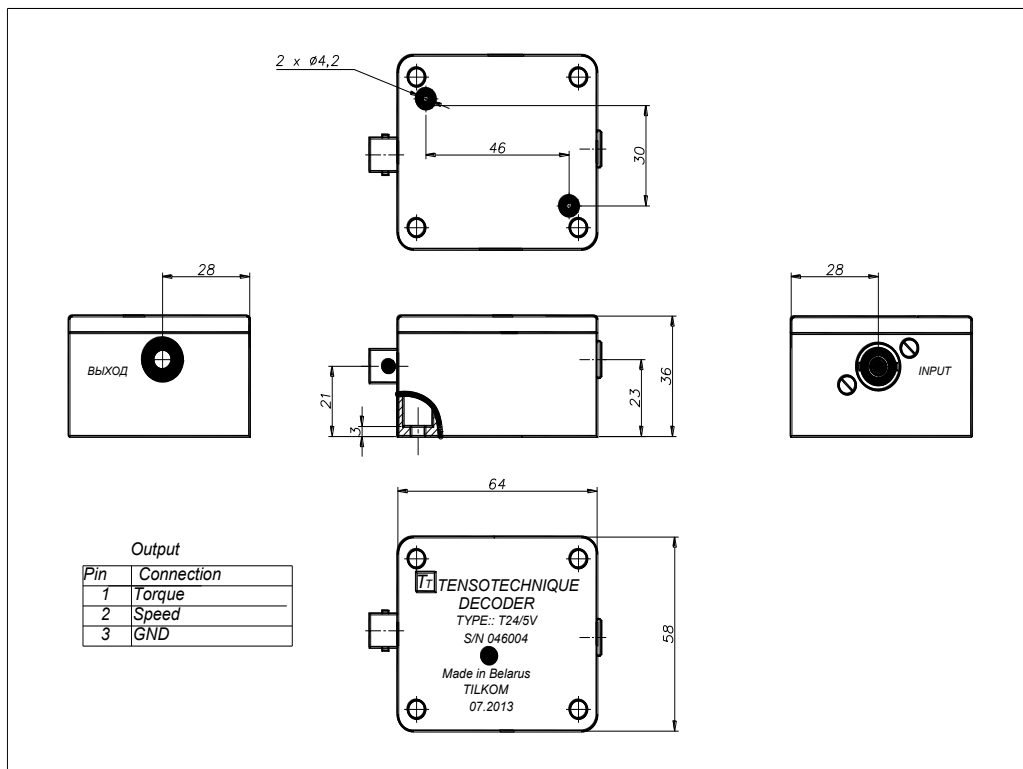

T23 frequency decoder. Dimensions in mm.

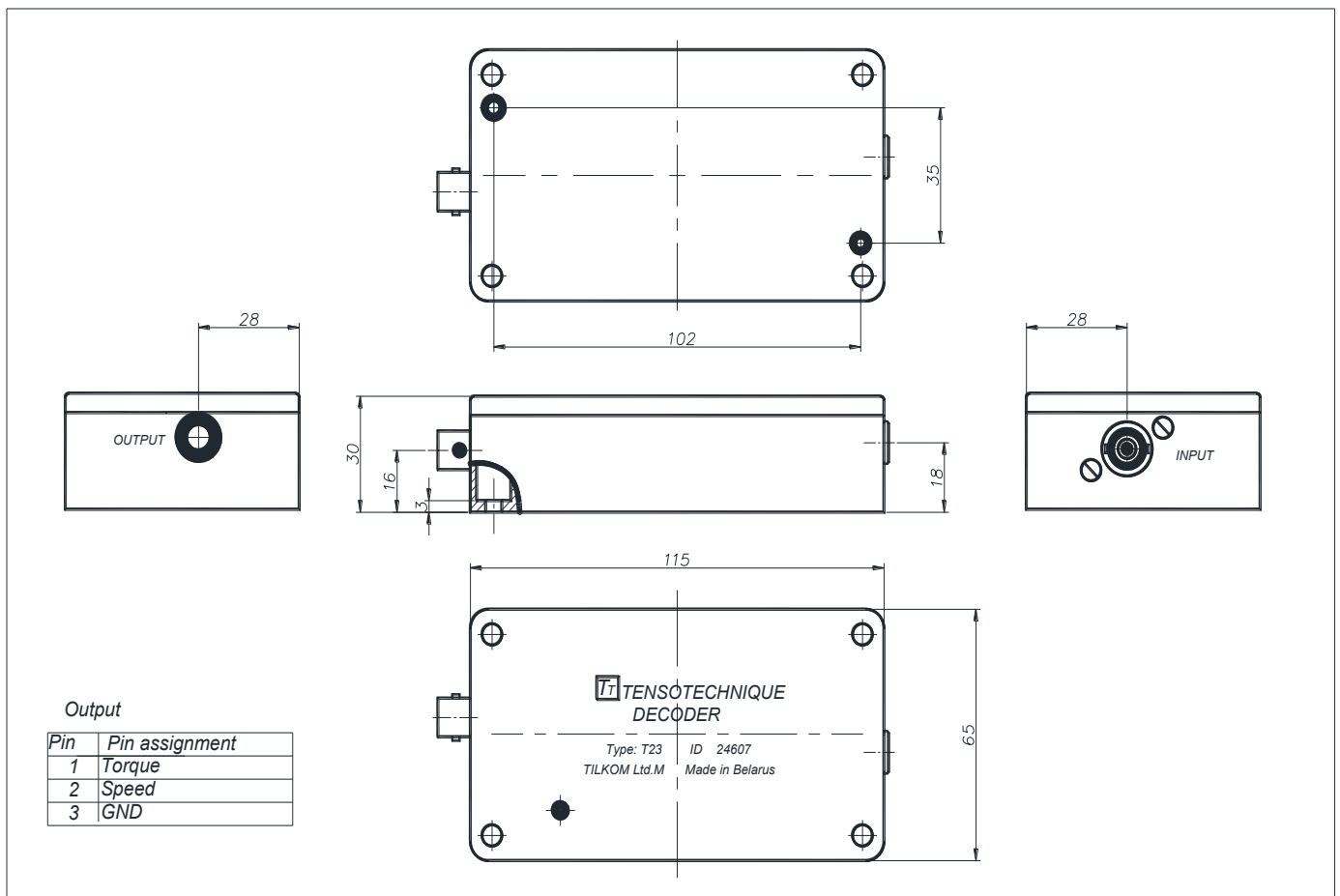

Software

The Windows-based software for M40H transducer enables the acquisition of measurement data and its storage in a file. The measurements can be visualized on-line with digital indicators and x/y displays. A text file is provided for storage so that the measurement data can be read and processed by other programs. The software provides auto identification of type of transducer, serial number, measuring range.

Features: support up to 8 (eight) transducers simultaneously, mathematical computation of mechanical power, rotation speed and torque, measurement signal filter and signal averaging, zero shift adjustment, fast records, slow records, scaling of x-axis and y-axis, digital indicator of high resolution, real-time display of measured values, their storage and playback. The software has a function of recording data without averaging at the maximum speed of receiving data; this enables you to analyze the dynamic processes.

Installation example

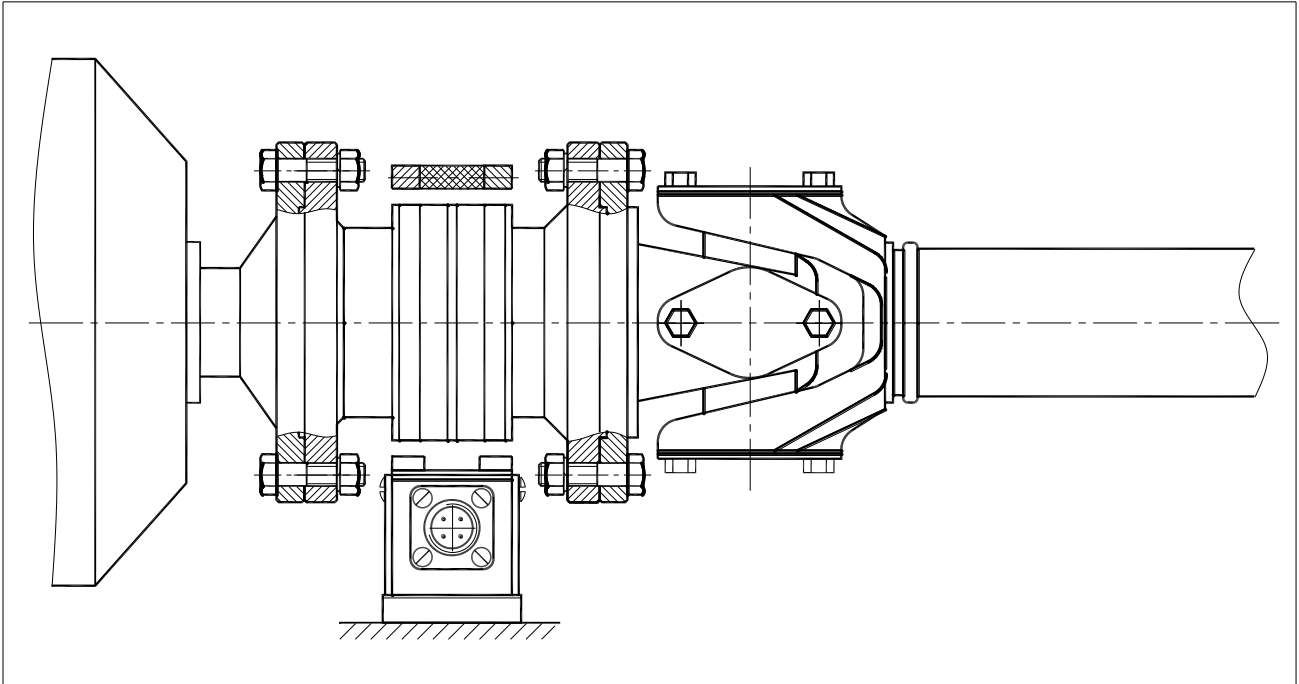

Electrical connections

1. Simultaneous use of a PC and the T40 (T41) display unit.

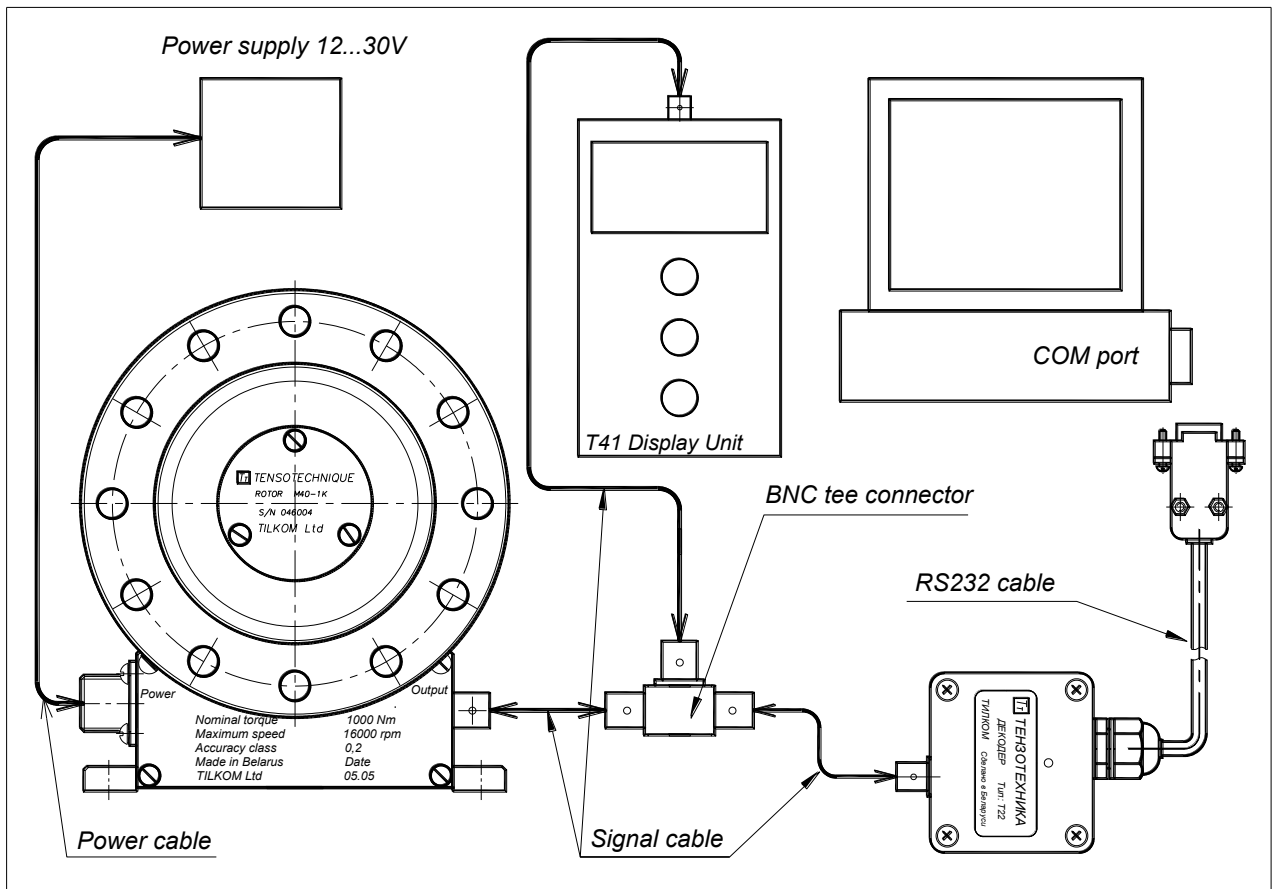

4. Connection to the T24 analogue decoder ($\pm 5\text{ V}$, $\pm 10\text{ V}$ or $4 \dots 20\text{ mA}$)

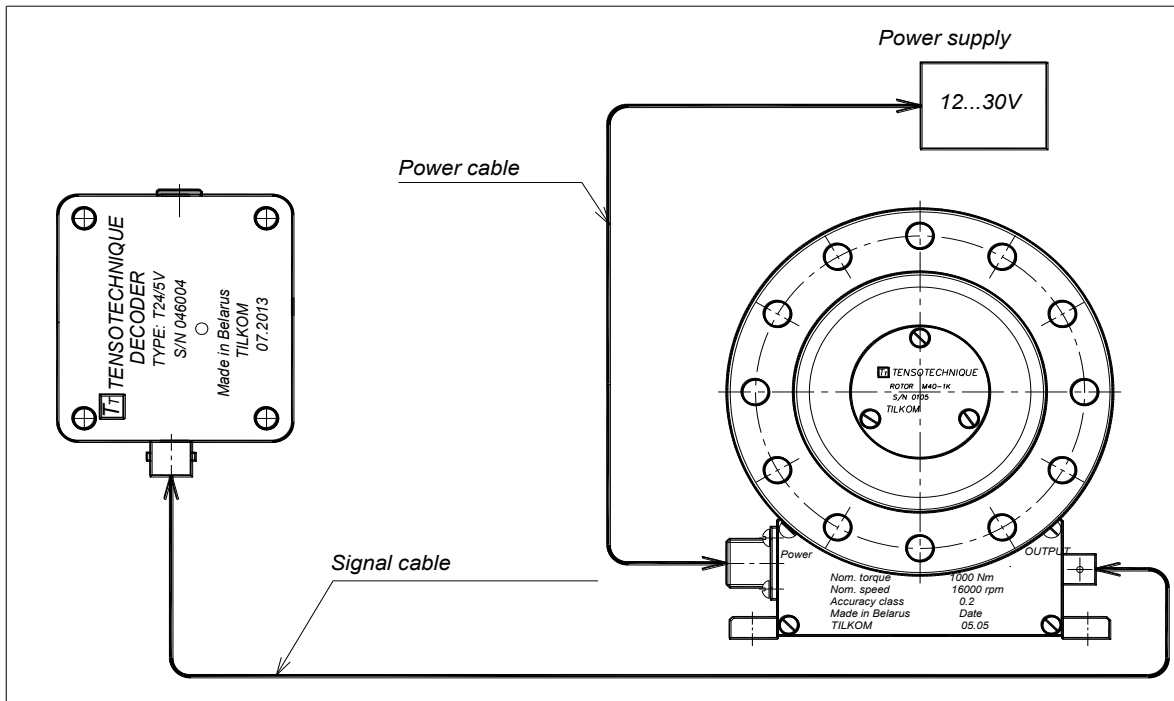

5. Connection to the T46 (RS485) decoder

