

MA20 Reaction Torque Transducer



The MA20 torque transducers are used to measure static and dynamic torque in a non-turning mode. They are suitable for use in testing machines as reaction torque transducers or in calibration devices as reference torque transducers.

The MA20 transducers operate on the strain gauge principle. They are equipped with a built-in amplifier and analogue-digital converter. It is also particularly noted for its extremely low sensitivity to parasitic influences, such as bending moments and transverse and axial forces. They measure static and dynamic (rapidly changing) torque with positive and negative polarity.

The MA20 torque transducers can have different output signals: digital (RS232, RS485 (Modbus RTU protocol), USB 2.0 interfaces), analogue ($\pm 5\text{ V}$, $\pm 10\text{ V}$, 4 ... 20 mA) and frequency ($10\text{ kHz} \pm 5\text{ kHz}$, $60\text{ kHz} \pm 30\text{ kHz}$). The MA20 can be connected to a PC to monitor the measurement process and to save the data. The appropriate software is in the scope of supply

Type-Survey

Type	Unit	Nominal Torque														
		0.1	0.2	0.5	1	2	3	5	6	8	10	12	15	20	25	30
MA20-0.1 ... 2	Nm															
MA20-3 ... 30																
MA20-50 ... 150																
MA20-200 ... 300																
MA20-400 ... 1.2k																
MA20-1.5 ... 2.5k	kNm															
MA20-3k ... 6k																
MA20-8k ... 15k																
MA20-20k ... 30k																
MA20-40k ... 60k																
MA80k ... 120k																
MA150k ... 300k																

Dimensions in mm

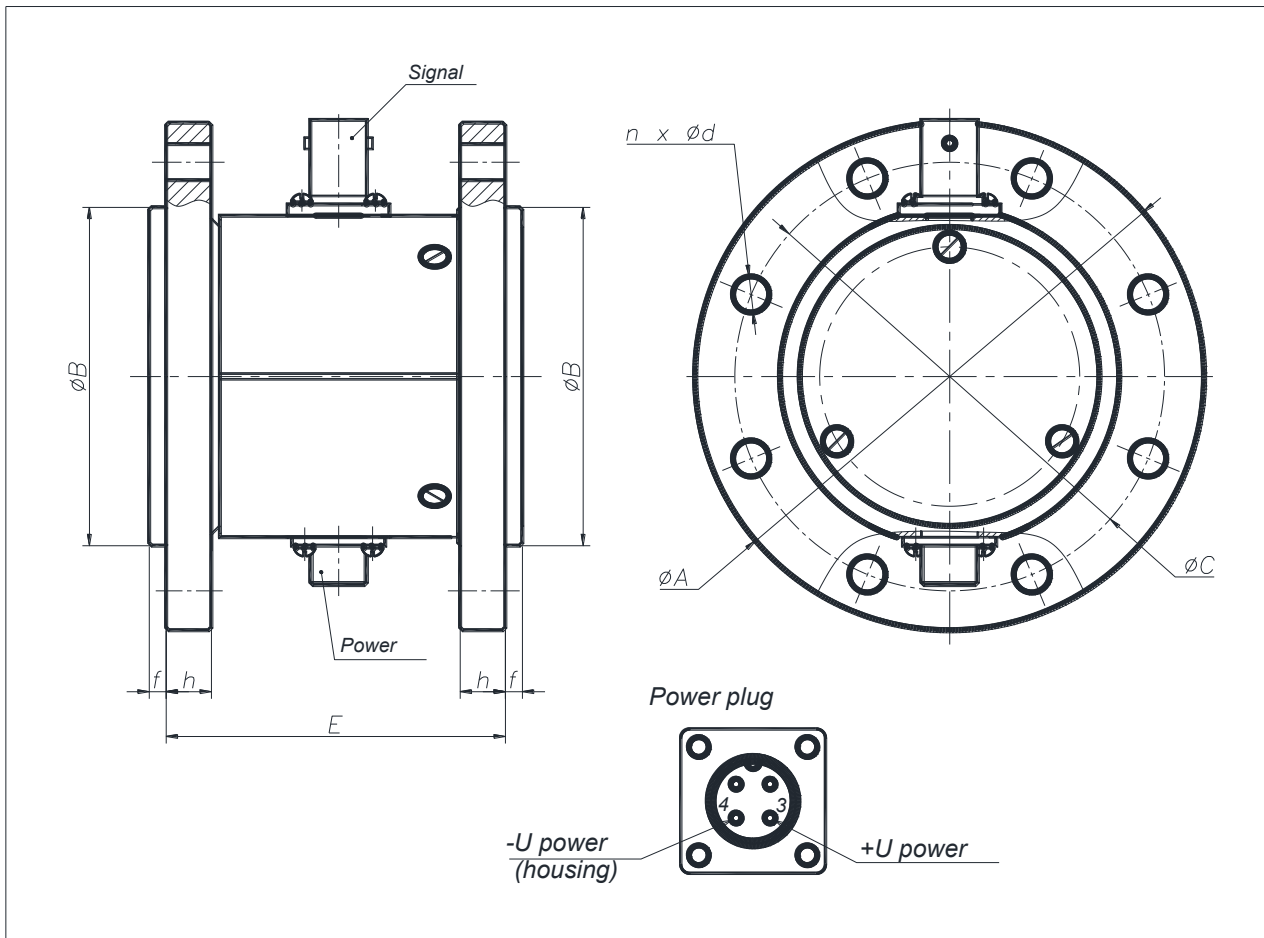

Type	$\varnothing A$	$\varnothing B$	$\varnothing C$	E	f	h	$\varnothing d$	n
MA20-0.1...2	45	30g6	38±0.10	54	2.5 ^{+0.1}	4.0	3.4H12	4
MA20-3...30	60	40g6	50±0.10	50	2.5 ^{+0.1}	5.5	4.5H12	8
MA20-50...150	78	50g6	66±0.10	60	3 ^{+0.14}	7.0	5.5H12	8
MA20-200...300	90	60g6	76±0.10	64	3 ^{+0.14}	8.0	6.5H12	8
MA20-400...1.2k	122	80g6	104±0.10	82	3 ^{+0.14}	12.0	8.5H12	12
MA20-1.5...2.5k	142	90g6	120±0.12	90	3 ^{+0.14}	15.0	10.5H12	12
MA20-3k...6k	175	110g6	150±0.25	100	3 ^{+0.14}	16.0	13H12	16
MA20-8k...15k	200	130g6	170±0.25	120	4 ^{+0.18}	20.0	17H12	16
MA20-20k...30k	238	160g6	204±0.25	150	4 ^{+0.18}	22.0	19H12	16
MA20-40k...60k	304	210g6	260±0.25	170	5 ^{+0.18}	28.0	25H12	16
MA20-80k...120k	380	250g6	320±0.25	192	6 ^{+0.22}	32.0	31H12	16
MA20-150k...300k	520	360g6	450±0.25	224	10 ^{+0.22}	39.0	38H12	16

Technical data

1. Nominal torque see table «Type-Survey».

2. Electrical and metrology parameters

Accuracy class		0.2
Deviation of the actual output signal at the nominal torque from the nominal value (including hysteresis and nonlinearity)	%	± 0.2
Temperature effect per 10 °C on the zero signal, related to the nominal output value	%	± 0.1
Nominal supply voltage	V (DC)	12 ... 30
Power consumption	W	< 5
Measurement frequency range	Hz	0 ... 1 000 (- 1.5 dB)
Amplitude ripple (0 ... 500 Hz)	dB	≤ 0.1
Frequency output (T23 decoder)		
Frequency output signal with positive nominal torque	kHz	15 (90)
Frequency output signal with negative nominal torque	kHz	5 (30)
Frequency output signal at torque = zero	kHz	10 (60)
Load resistance	kΩ	≥ 2
Output voltage	V	5 ± 1 (symmetrical meander)
Input-output galvanic isolation		+
Analogue output (T24 decoder)		
Nominal output signal with positive (right-hand) nominal torque	V	+ 5 (+ 10)
Nominal output signal with negative (left-hand) nominal torque	V	- 5 (- 10)
Output signal at torque = zero	V	0
Load resistance	kΩ	≥ 10
Analogue output (T24/4 ... 20 mA decoder)		
Output current	mA	4...20
Output current at loading = zero	mA	12
Output current at nominal positive loading	mA	20
Output current at nominal negative loading	mA	4
Load resistance	kΩ	≥ 100
Digital output (T45 decoder)		
Interface		USB 2.0
Data transfer rate (Full-Speed)	Mbit/sec	12
Sample rate	kSample	5.0
Input-output galvanic isolation		+
Digital output (T37 decoder)		
Interface		Ethernet
Data transfer rate	Mbit/sec	10; 100
Sample rate	kSample	5.0
Input-output galvanic isolation		+
Digital output (T46 decoder)		
Interface		RS485
Protocol		MODBUS RTU
Data transfer rate	baud	2 400 - 115 200
Parity check		+
Sample rate	kSample	5.0
Input-output galvanic isolation		+
Digital output (T42 decoder)		
Interface		RS232
Data transfer rate	baud	2 400 - 115 200
Parity check		+
Sample rate	kSample	5.0
Input-output galvanic isolation		+

3. Parameters of resistance to environment and mechanical exposures

Nominal temperature range	°C	0 ... + 60
Relative humidity	%	≤ 95 (+ 35 °C)
Air pressure	kPa	84 ... 106.7 (630 ... 800 mm Hg)
Storage temperature range	°C	- 10 ... + 70
Storage humidity	%	95 (+ 30 °C)
Vibration resistance:		
Frequency range	Hz	10 ... 55
Duration	h	1
Acceleration	m/s ²	40
Impact resistance:		
Number of impacts	n	1 000
Duration	ms	10
Acceleration	m/s ²	400
Degree of protection		IP40

4. Permissible load limits and mechanical values

Nominal torque M _N	Nm	0.1-0.2	0.5-1	1-2	3-5	10-30	50-100	200-300	400-1 200	1 500-2 500
Axial limit force	kN	0.1	0.2	0.3	0.5	1.0	1.5	3	8	16
Lateral limit force	N	2	3	5	10	40	120	220	1 000	2 000
Bending limit moment	Nm	0.1	0.2	0.3	0.5	2	10	20	80	150
Torsional stiffness	kNm/rad	0.02	0.12	0.20	0.50	3.50	31.0	51.0	480	710
Weight	kg	0.1	0.2	0.2	0.5	0.5	1.0	1.3	3.1	4.7

Nominal torque M _N	kNm	3-6	8-15	20-30	40-60	80-100	120-150	200-300
Axial limit force	kN	28	32	80	120	180	180	220
Lateral limit force	kN	5	10	25	50	80	80	120
Bending limit moment	kNm	0.6	0.6	1.2	2	4	4	6
Torsional stiffness	kNm/rad	3 150	4 240	13 020	18 000	26 000	29 000	88 000
Weight	kg	8.0	13.0	22.0	38.1	57.0	68.0	180.0

Limit torque, related to M_N

Type	Unit	Nominal Torque										Limit torque related to M _N , %	
MA20-0.1 ... 2	Nm	0.1	0.2	0.5	1	2						150	
MA20-3 ... 30		3	5	6	8	10	12	15	20	25	30		
MA20-50 ... 150		50	60	80	100	150							
MA20-200 ... 300		200	250	300									
MA20-400 ... 1.2k		400	500	600	800	1 000	1 200						
MA20-1.5 ... 2.5k	kNm	1.2	1.5	2	2.5							120	
MA20-3k ... 6k		3	5	6									
MA20-8k ... 15k		8	10	15	12								
MA20-20k ... 30k		20	25	30									
MA20-40k ... 60k		40	50	60									
MA80k ... 100k		80	100										
MA120k ... 150k		120	150										
MA200k ... 300k		200	250	300									

Axial force, radial force and bending moment have to be reduced according to graph below, if they act together.

To prevent from excessive stress due to misalignment and thermal influences the transducer should be fitted between flexible couplings. We offer such flexible torsionally rigid couplings MK series. Technical specification see in the data sheet entitled "MK Couplings".

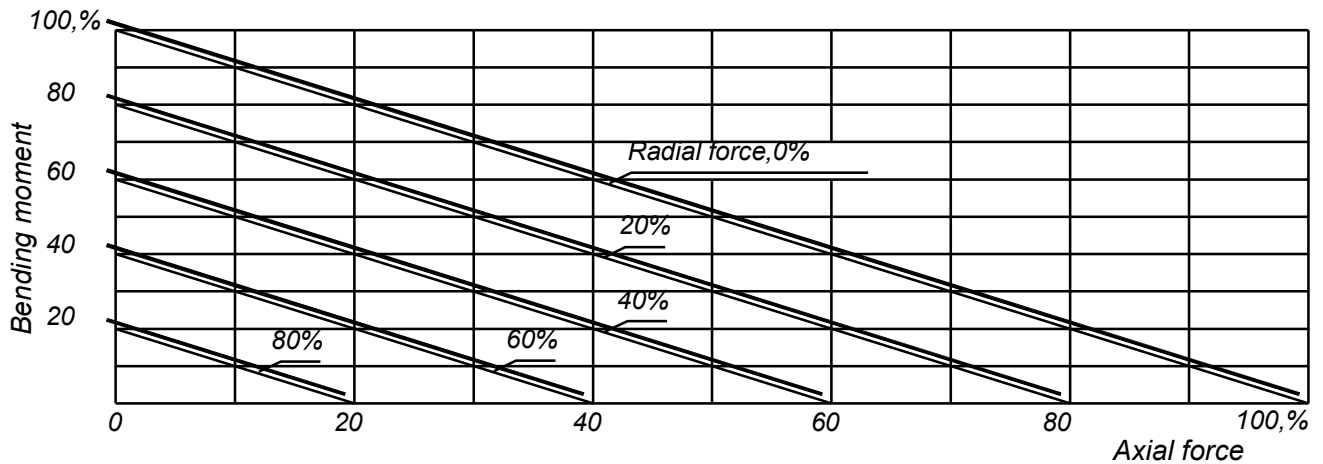

Scope of delivery

MA20 torque transducer	1
Txx decoder	1
Output signal cable, 5 m long (optionally can be over in length)	1
Power supply connector (PC4 or 2PM14)	1
"Transducer" software for Windows XP, 7, 8, 10	1
Software user manual	1
Operating manual	1

Accessories (to be ordered separately and optionally)

MK flexible torsionally rigid couplings	2
T40 display unit	1
T41 display unit (plastic case)	1
T50 display unit	1
T24 analogue decoder (± 5 V, ± 10 V or 4... 20 mA)	1
T23 frequency decoder (10 ± 5 kHz or 60 ± 30 kHz)	1
T45 digital decoder (USB 2.0)	1
T42 digital decoder (RS232)	1
T46 digital decoder (RS485)	1
T37 digital decoder (Ethernet)	1
AC/DC adapter (12 ... 30 V)	1

T42, T45, T46 digital decoder. Dimension in mm

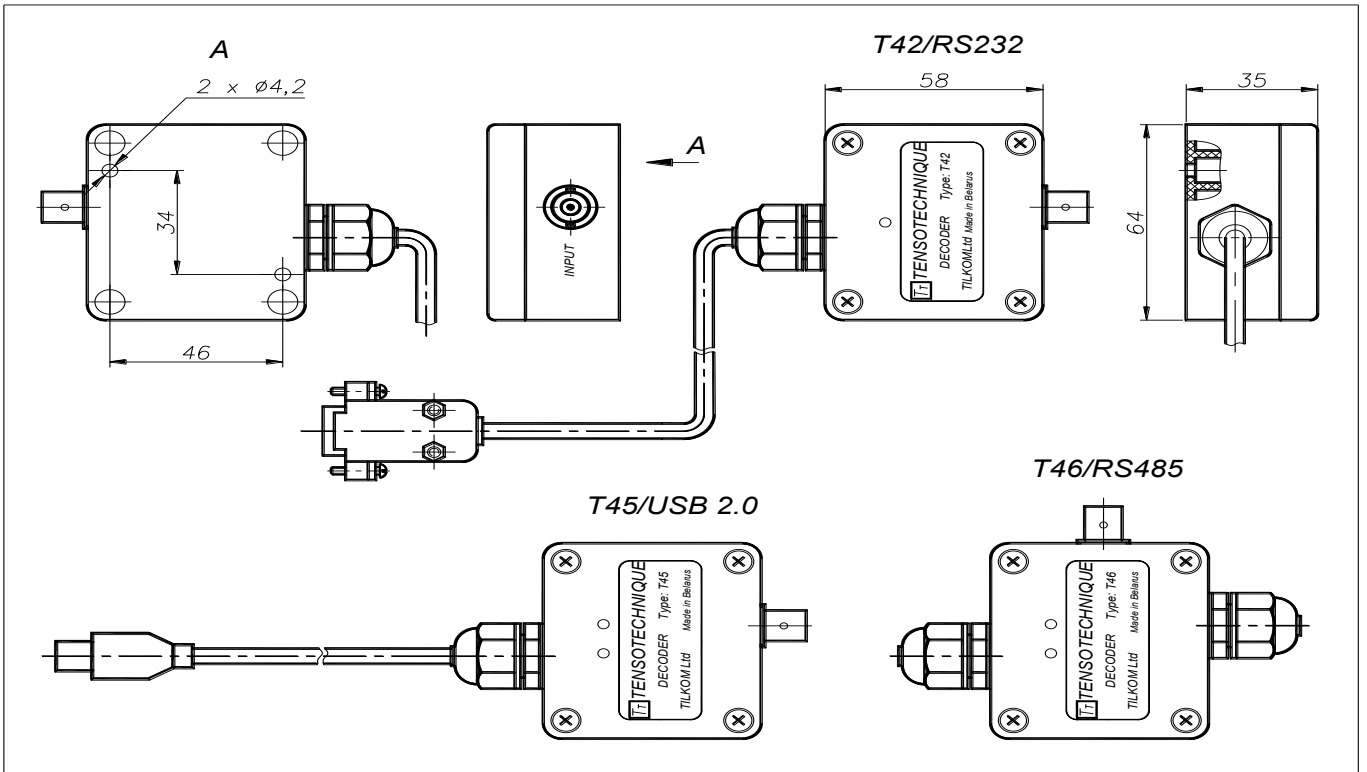

T24 analogue decoder. Dimension in mm

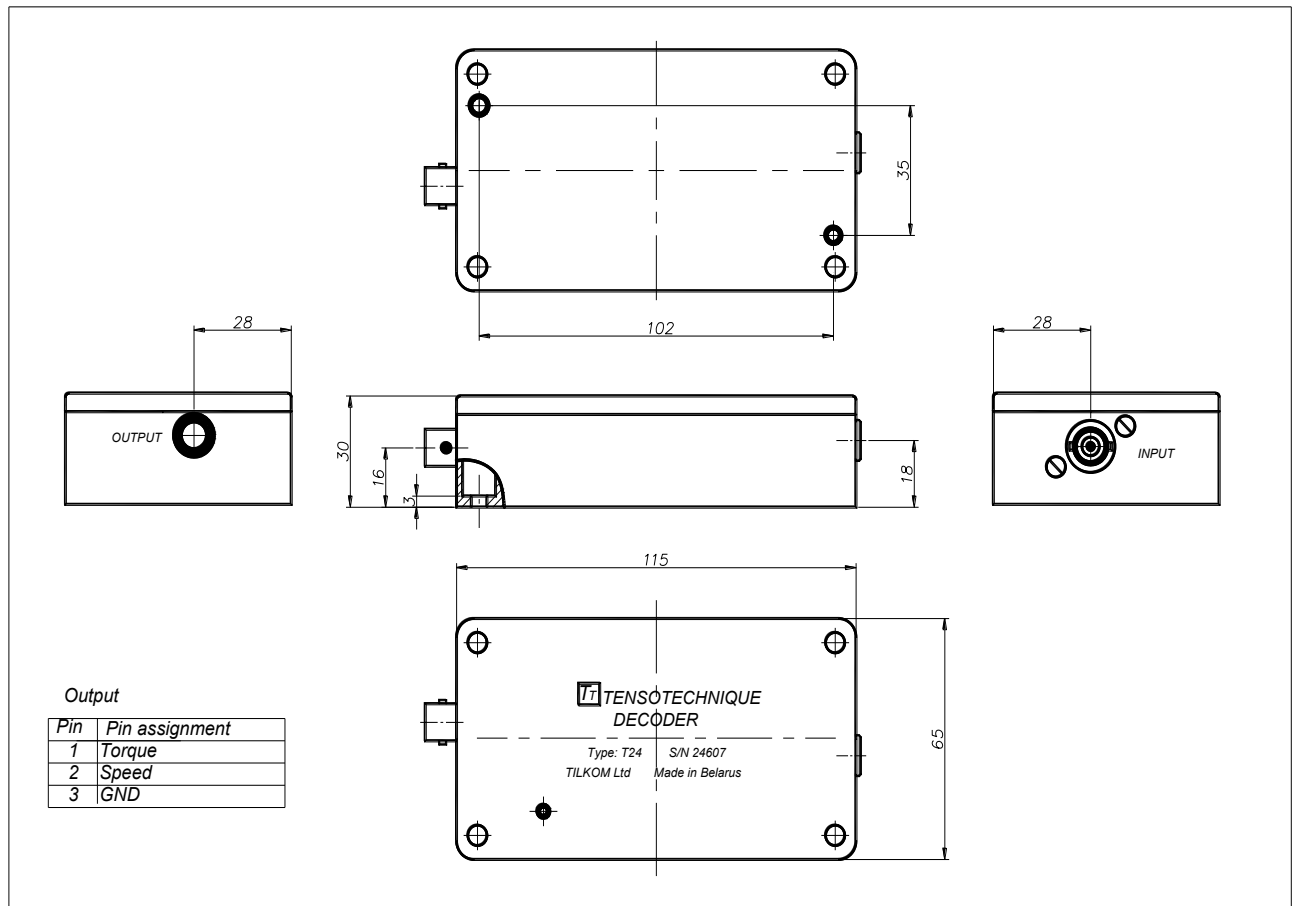

T23 frequency decoder. Dimensions in mm.

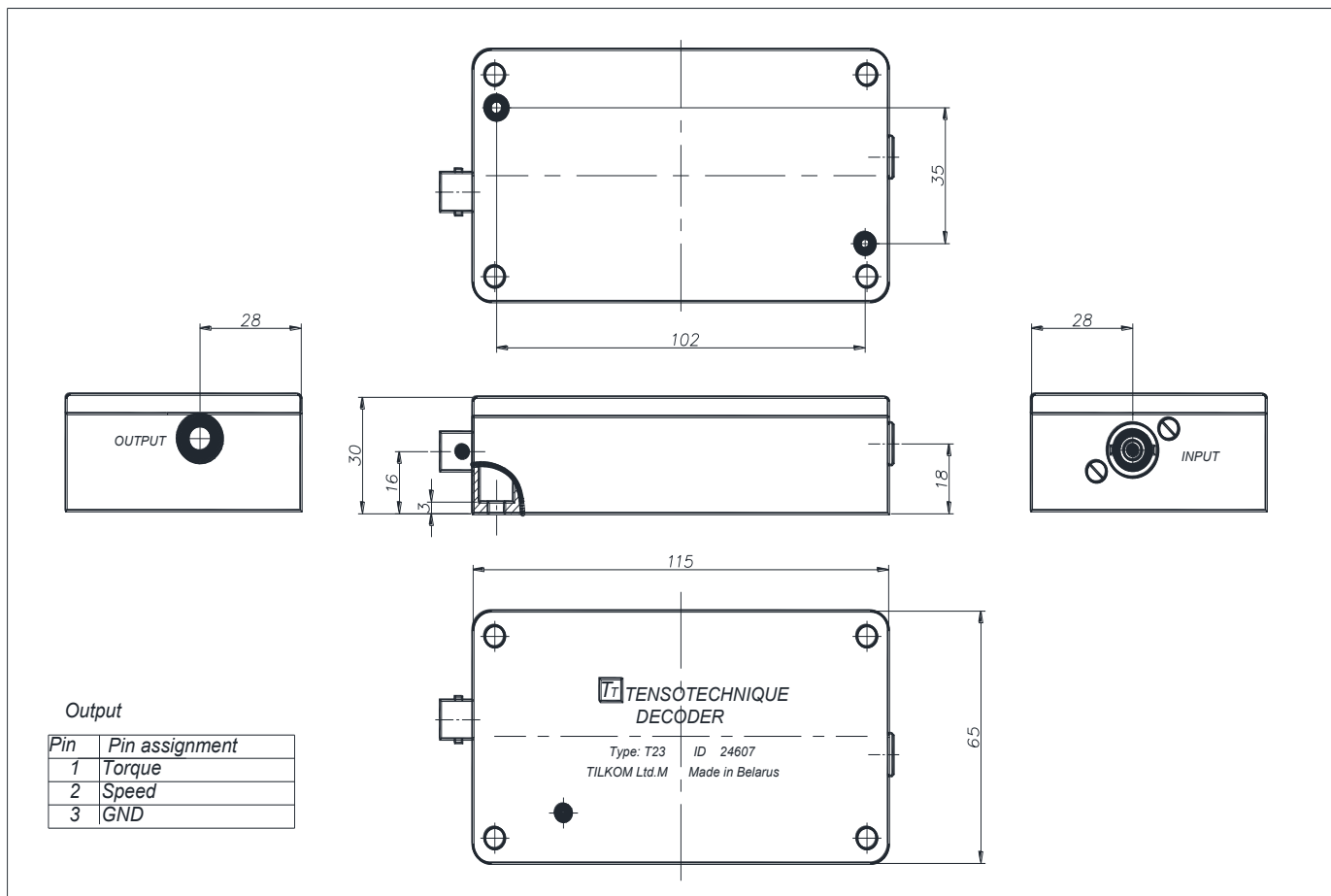

Software

The Microsoft® Windows-based software for MA20 torque transducer enables the acquisition of measurement data and its storage in a file. The measurements can be visualized on-line with digital indicators and x/y displays. A text file is provided for storage so that the measurement data can be read and processed by other programs. The software provides auto identification of type of transducer, serial number, measuring range.

Features: support up to 4 (four) transducers simultaneously, mathematical computation of mechanical power, rotation speed and torque, measurement signal filter and signal averaging, zero shift adjustment, fast records, slow records, scaling of x-axis and y-axis, digital indicator of high resolution, real-time display of measured values, their storage and playback. The software has a function of recording data without averaging at the maximum speed of receiving data; this enables you to analyze the dynamic processes.

Electrical Connection

1. Connection to a PC via COM-port (T42 decoder)

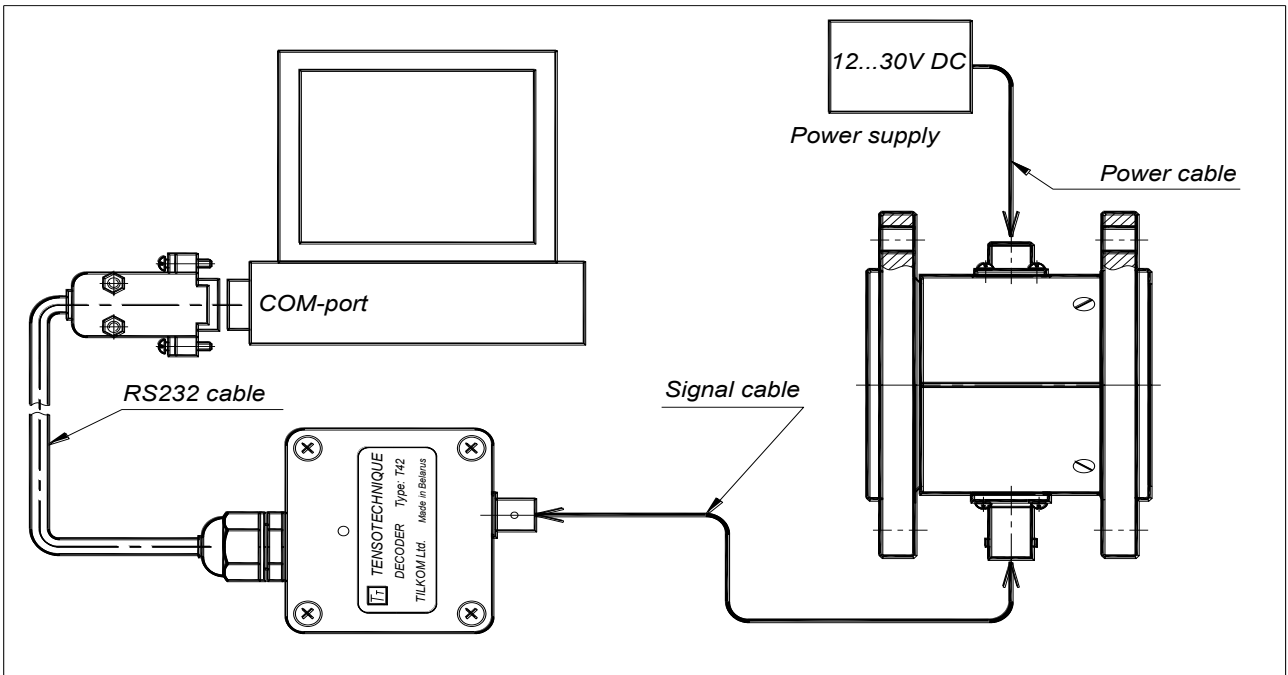

2. Simultaneous use of a PC and the T40 (T41) display unit

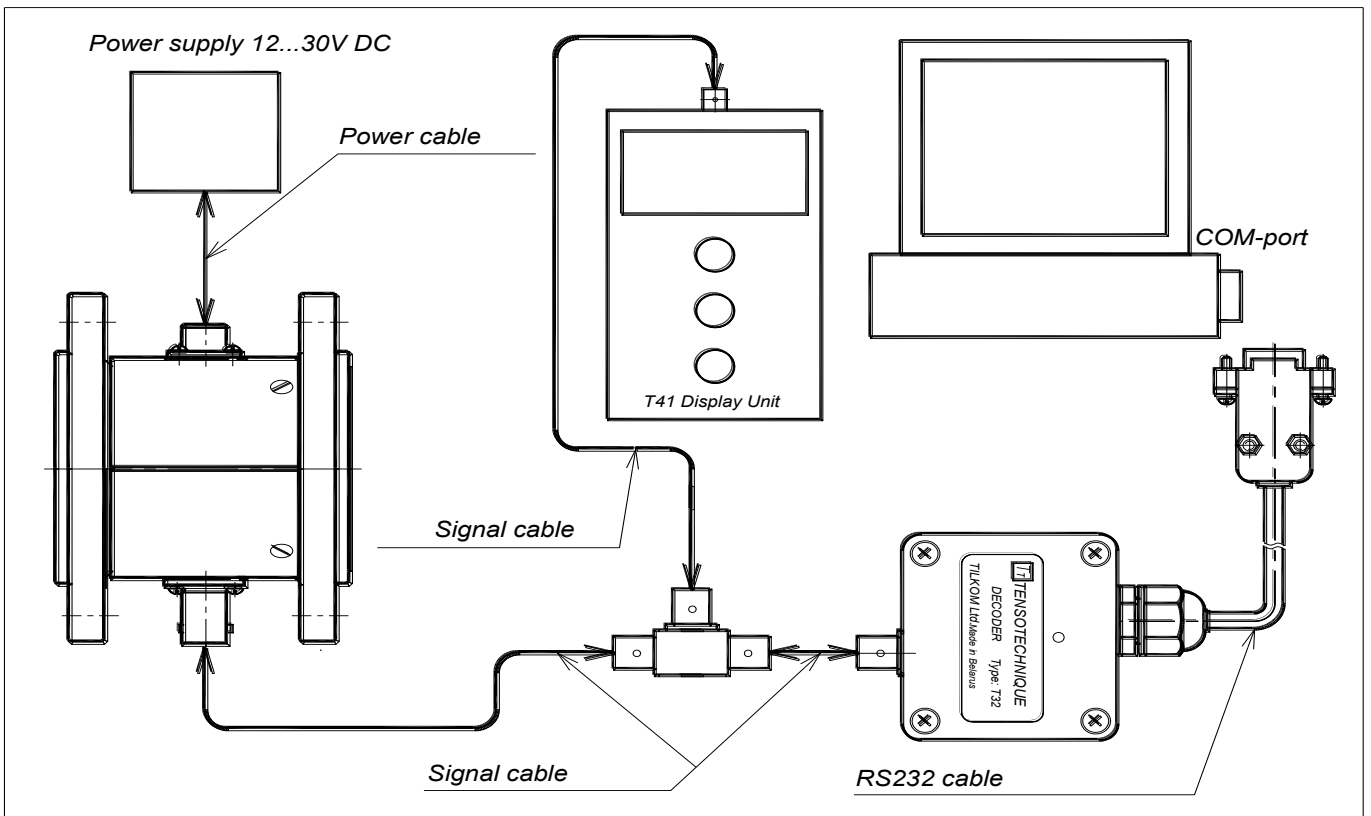

3. Connection to an USB-port (T45 decoder)

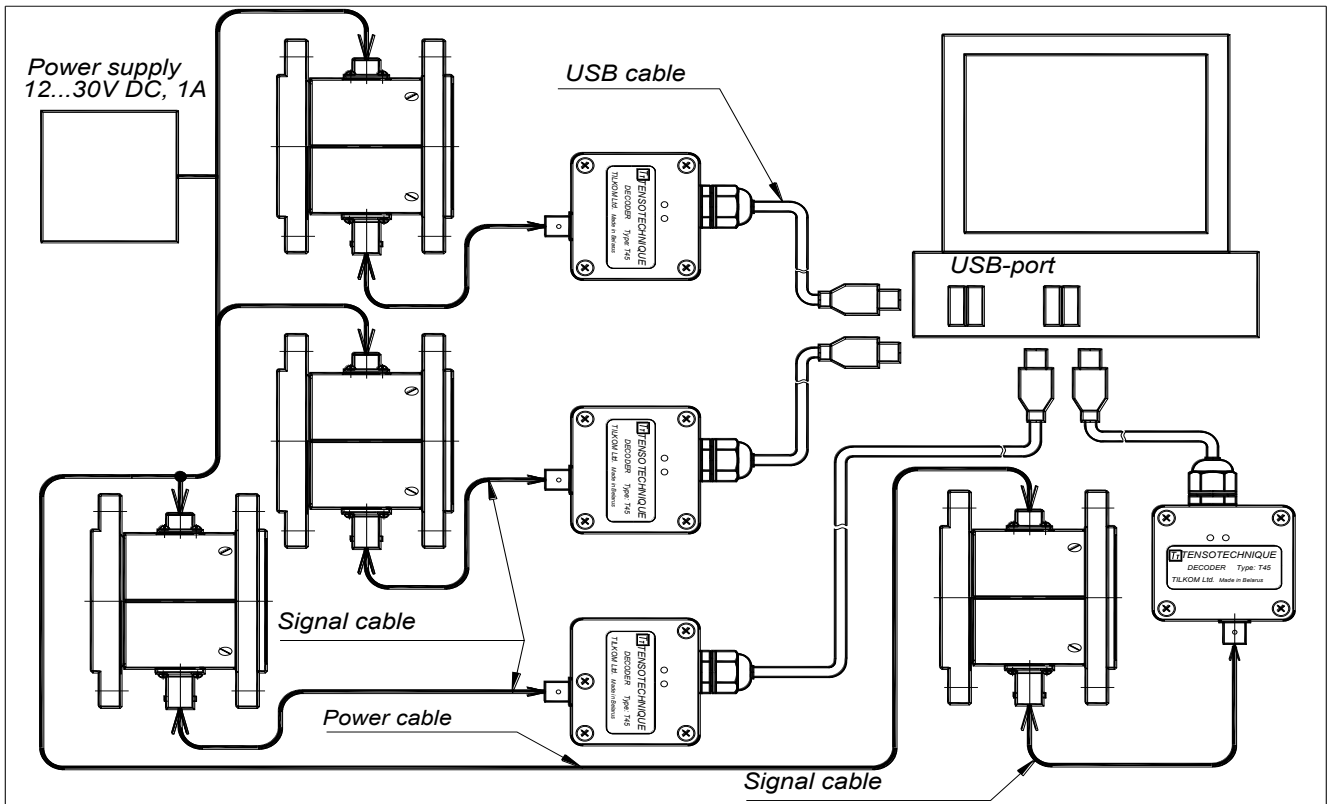

4. Connection to the T40 display unit

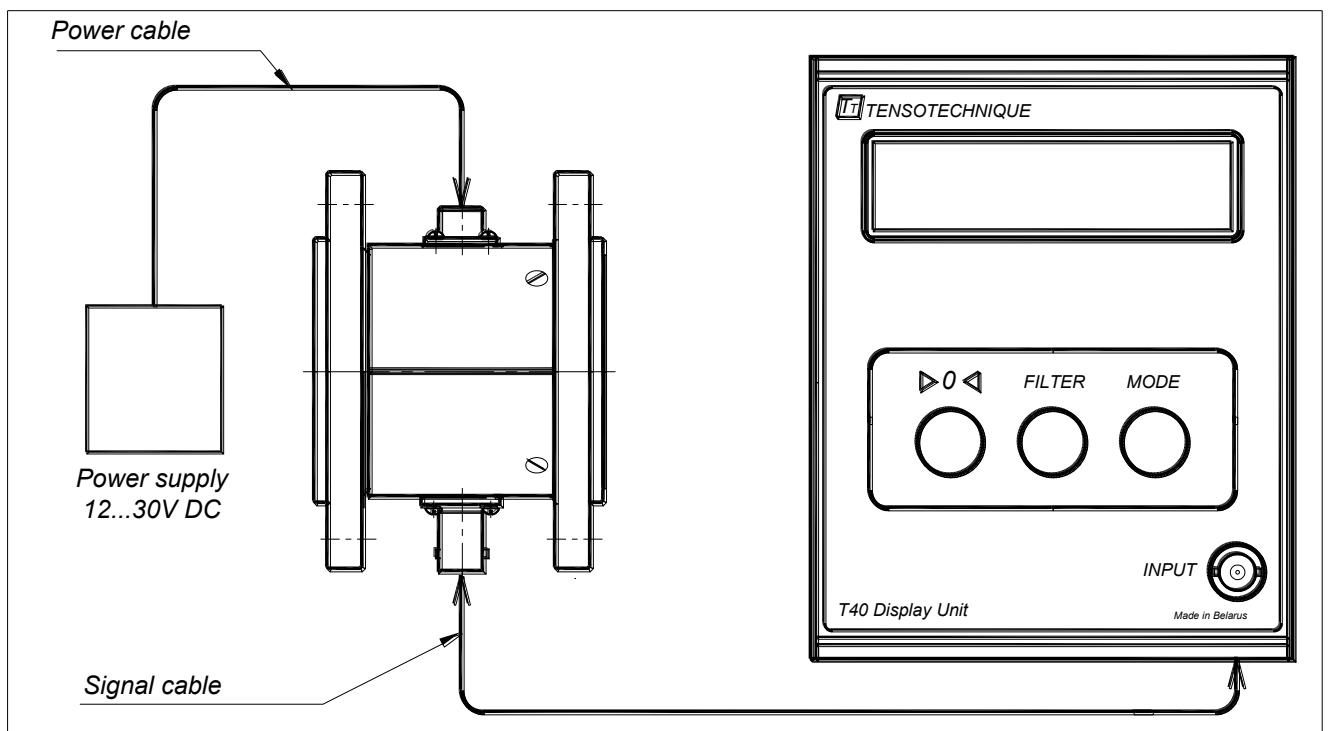

5. Connection to the T24 analogue decoder ($\pm 5\text{ V}$, $\pm 10\text{ V}$ or $4\text{...}20\text{ mA}$)

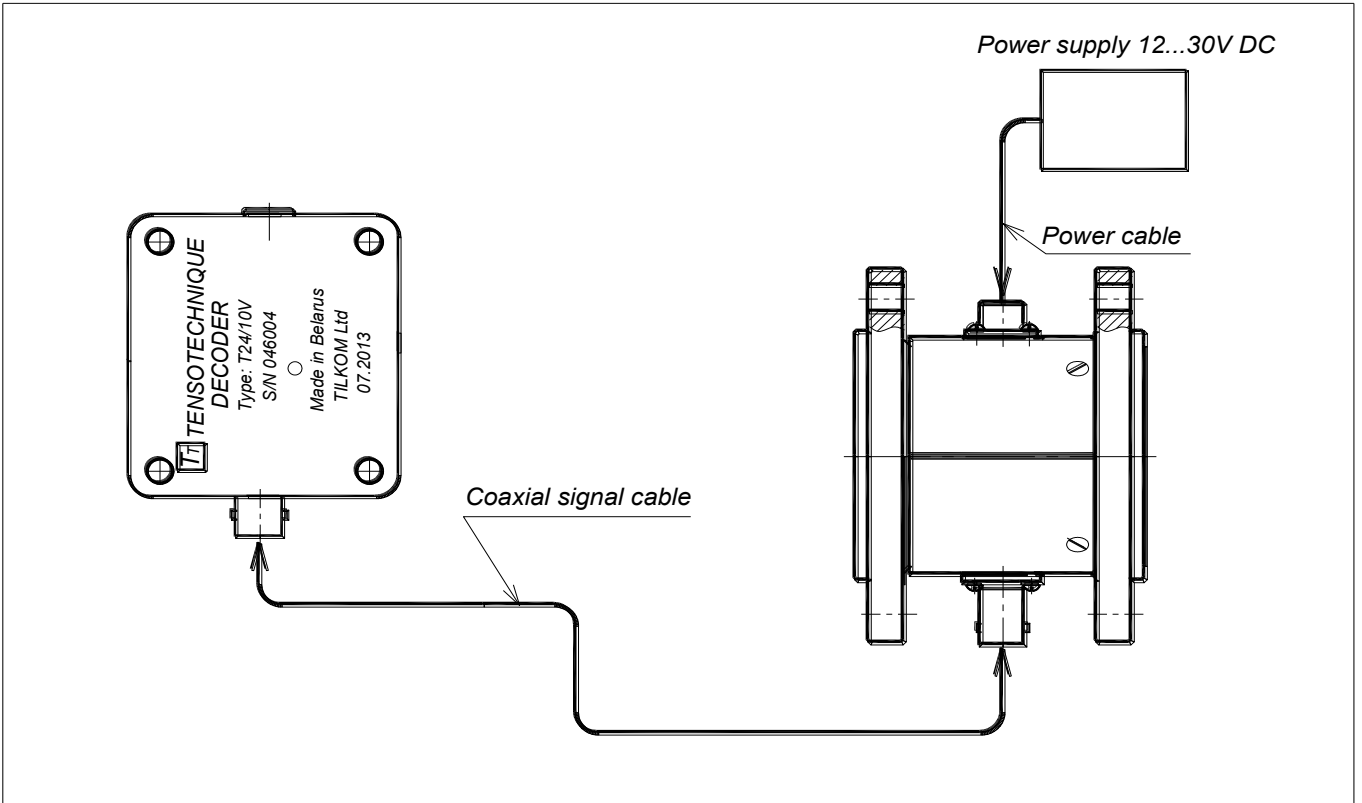

6. Connection to the T46 (RS485) decoder

